



**STEELER**

**SOKÓŁKA**

***www.steeler.pl***

# **VOLKSWAGEN AMAROK**



## **INSTRUKCJA MONTAŻU**

(Płyta wciągarki)

## **FITTING INSTRUCTION**

(Winch plate)

## **инструкция монтажа**

(Лебедка пластины)

## **MONTAGEANLEITUNG**

(Winch Platte)

**AMAROK-PW**  
**AMAROKV6-PW**

**Wykaz elementów:**  
**Specification of full assembly:**  
**Список элементов тюнинга:**  
**Liste der Elemente:**

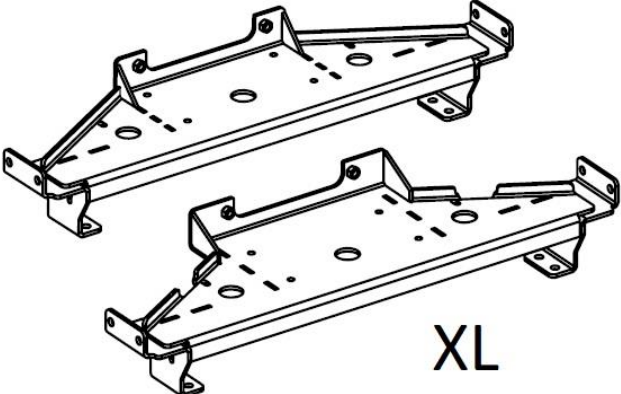
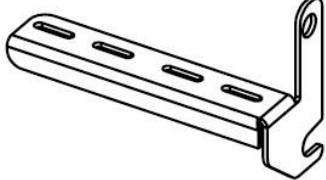
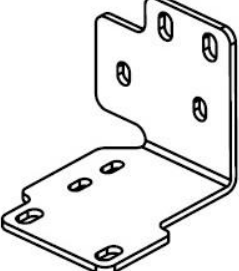
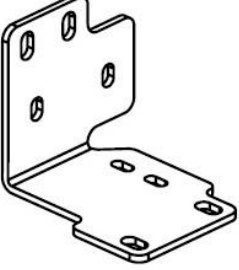
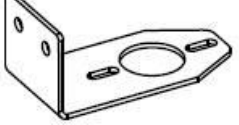
<p><b>1.</b> Płyta wciągarki (szt. 1) Winch plate (1 pcs.) Лебедка пластины (шт.1) Winch Platte (st.1)</p>	
<p><b>2.</b> Zamocowanie I (szt. 1) Attachment I (1 pcs.) Крепление I (шт.1) Montage I (st.1)</p>	
<p><b>3.</b> Zamocowanie prawe II (szt. 1) Right attachment II (1 pcs.) Крепление правое II (шт.1) Montage rechts II (st.1)</p>	
<p><b>4.</b> Zamocowanie lewe II (szt. 1) Left attachment II (1 pcs.) Крепление левое II (шт.1) Montage links II (st.1)</p>	
<p><b>5.</b> Zamocowanie III (szt. 2) Attachment III (2 pcs.) Крепление III (шт.2) Montage III (st.2)</p>	

**Wykaz elementów łącznych:**  
**Connecting components:**  
**Список соединительных элементов:**  
**Die Auflistung der Elemente:**

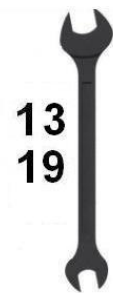
Śruby (szt.) Screws (pcs.) Болты (шт.) Schrauben (st.)	M8x35 – (4) M12x40 – (4) M12x50 – (4)	Nakrętki (szt.) Nuts (pcs.) Гайки (шт.) Muttern (st.)	M12 - (8)
Podkładki (szt.) Washers (pcs.) Шайбы (шт.) Unterlegscheiben(st.)	Ø 8,5 – (4) Ø 13 – (16)–XL		

M5 - 8 Nm	M6 - 11 Nm	M8 - 25 Nm	M10 - 50 Nm	M12 - 87 Nm
-----------	------------	------------	-------------	-------------



Czas montażu  
Fitting time  
Время монтажа  
Montagezeit



**4,5h**

***UWAGA: Folię usunąć dopiero po montażu!***  
***ATTENTION: Foil remove after fitting!***  
***ВНИМАНИЕ: Целлофан снять только после завершения монтажа!***  
***HINWEIS: Die Folie soll erst nach der Montage entfernt werden!***

**Montaż / Fitting / Монтаж / Montage**  
**AMAROK-PW**

	Śruby (szt.) Screws (pcs.) Болты (шт.) Schrauben (st.)	Podkładki (szt.) Washers (pcs.) Шайбы (шт.) Unterlegscheiben (st.)	Nakrętki (szt.) Nuts (pcs.) Гайки (шт.) Muttern (st.)
<b>A</b>	<i>M8x35</i>	<i>Ø8,5</i>	-----
<b>B</b>	<i>M12x40</i>	<i>Ø13(x2)</i>	<i>M12</i>
<b>C</b>	<i>M12x50</i>	<i>Ø13(x2)</i>	<i>M12</i>

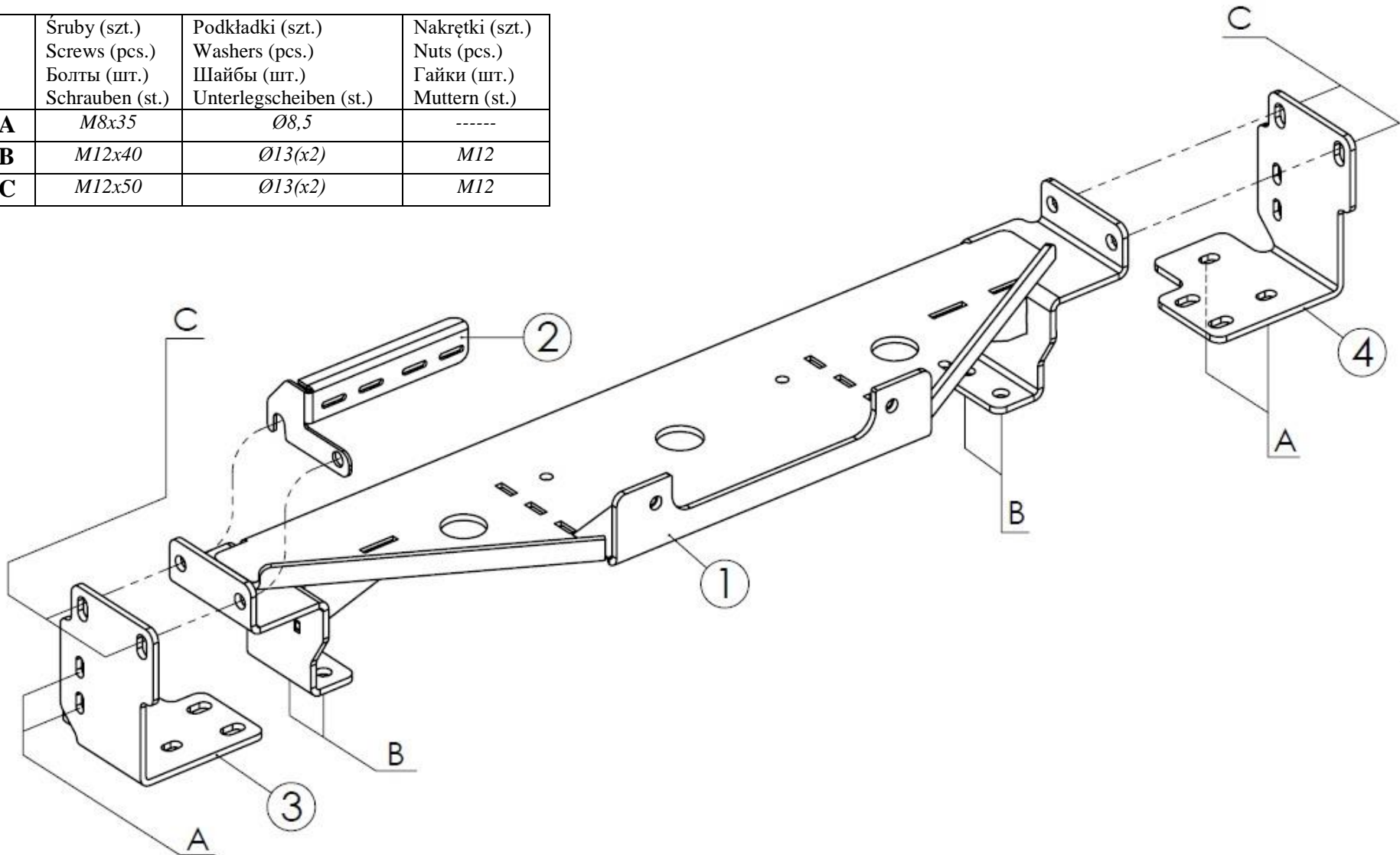

13,1 kg

**Montaż / Fitting / Монтаж / Montage**  
**AMAROKV6-PW**

	Śruby (szt.) Screws (pcs.) Болты (шт.) Schrauben (st.)	Podkładki (szt.) Washers (pcs.) Шайбы (шт.) Unterlegscheiben (st.)	Nakrętki (szt.) Nuts (pcs.) Гайки (шт.) Muttern (st.)
<b>A</b>	<i>M8x35</i>	<i>Ø8,5</i>	-----
<b>B</b>	<i>M12x40</i>	<i>Ø13(x2)</i>	<i>M12</i>
<b>C</b>	<i>M12x50</i>	<i>Ø13(x2)</i>	<i>M12</i>

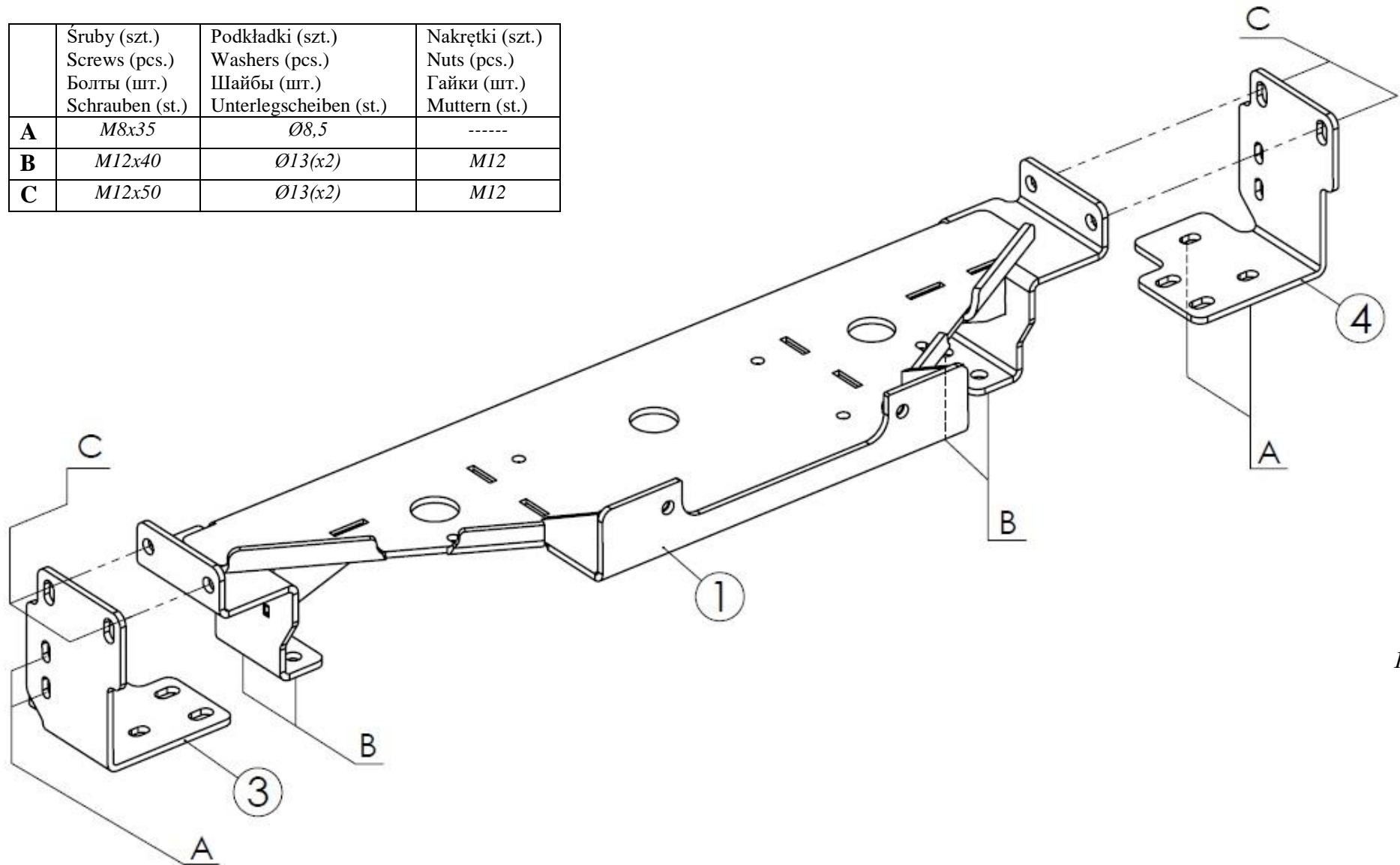

15,7 kg

**Montaż / Fitting / Монтаж / Montage**

Мосowanie pilota i hebla ; Attachment to the control switch and the security main breaker ;  
Крепление к удаленному / к выключатель; Die Befestigung an dem Entfernten / Leistungsschalter

Montowanie hebla pod maską  
Mounting the security main breaker

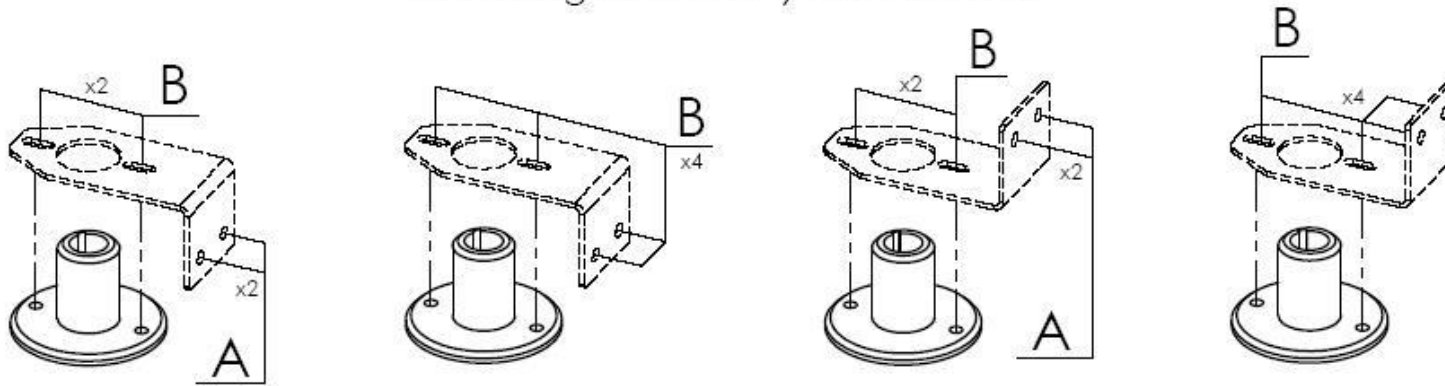

Montowanie pilota pod maską  
Mounting the control switch

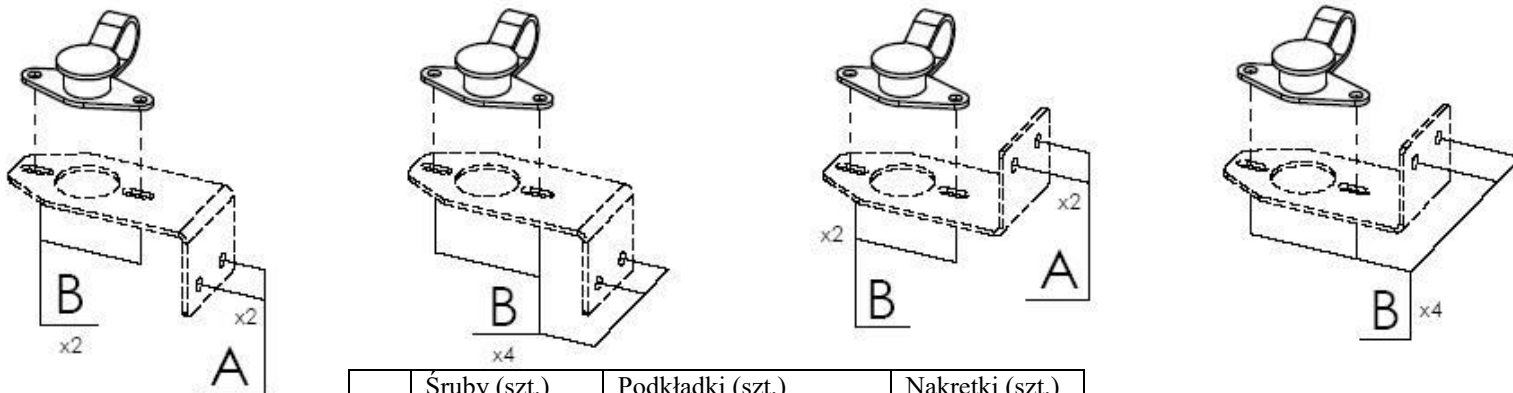

	Śruby (szt.) Screws (pcs.) Болты (шт.) Schrauben (st.)	Podkładki (szt.) Washers (pcs.) Шайбы (шт.) Unterlegscheiben (st.)	Nakrętki (szt.) Nuts (pcs.) Гайки (шт.) Muttern (st.)
<b>A</b>	M4,2x16	.....	.....
<b>B</b>	M5x20	Ø5 – XL	M5



## AMAROK-PW

*Montaż (zdjęcia) / Fitting (pictures) / Монтаж (фотографии)  
/ Montage (Fotos)*

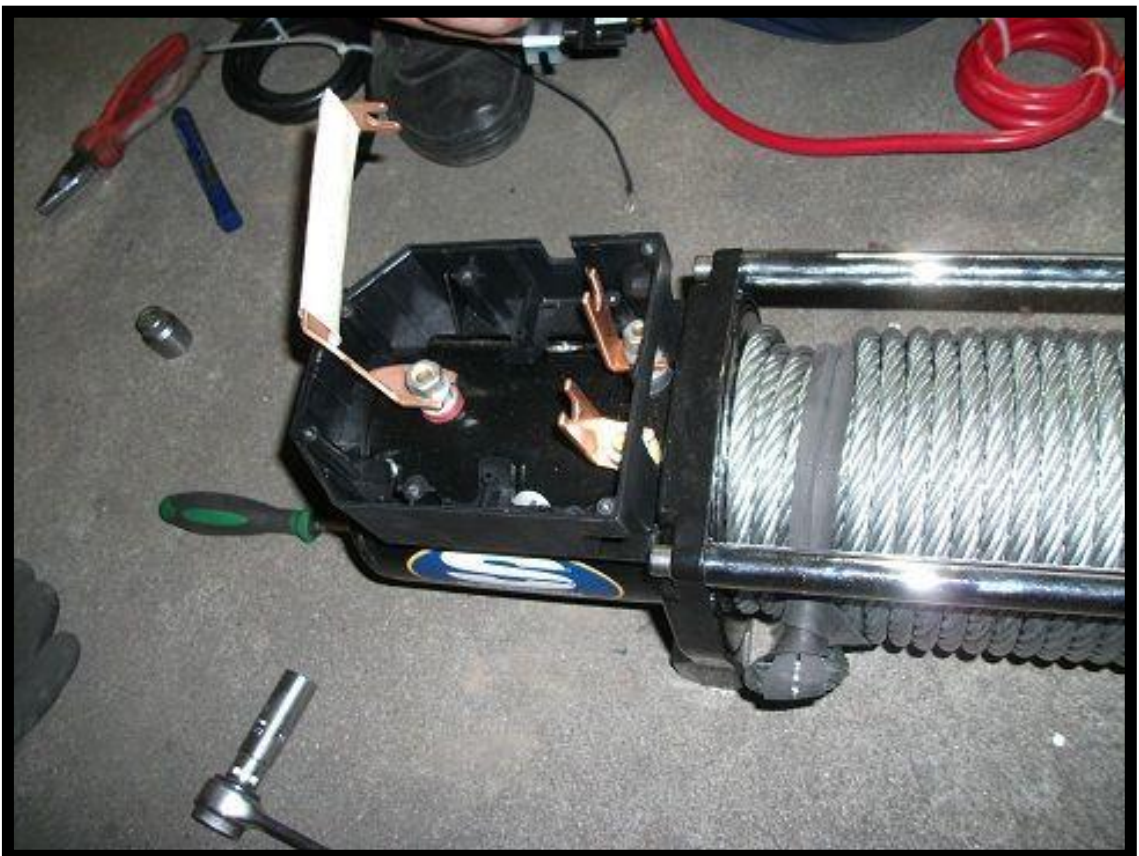
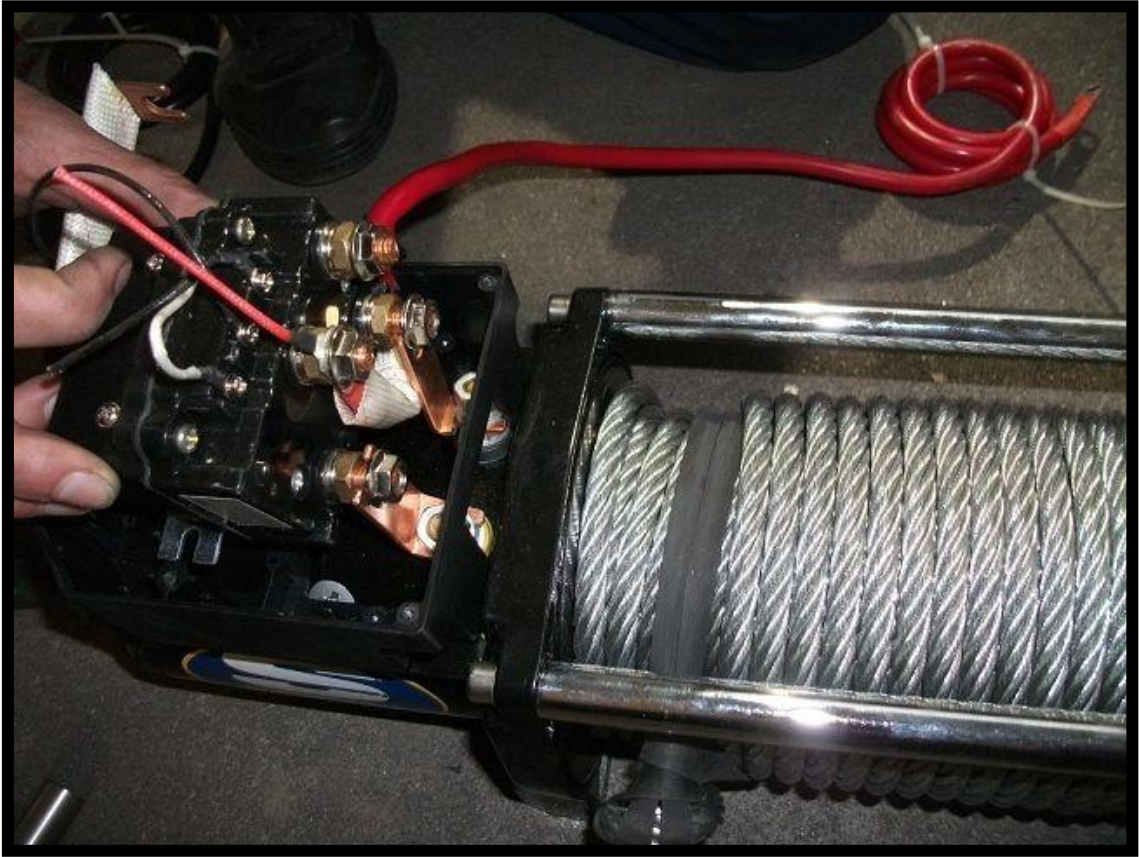





**Dla wersji V8 / *For the version V8***





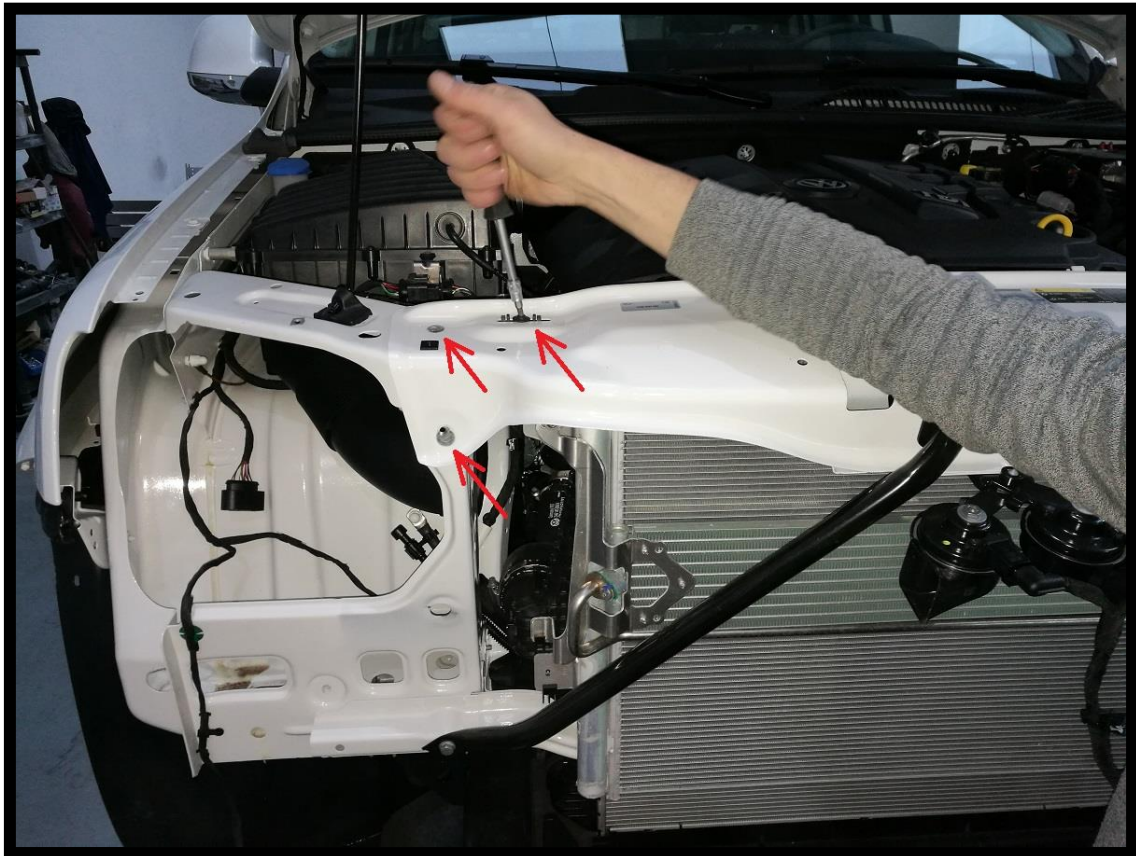

Odkręcić 3 śruby TORX z każdej strony  
*Unscrew 3 Torx screws on each side*

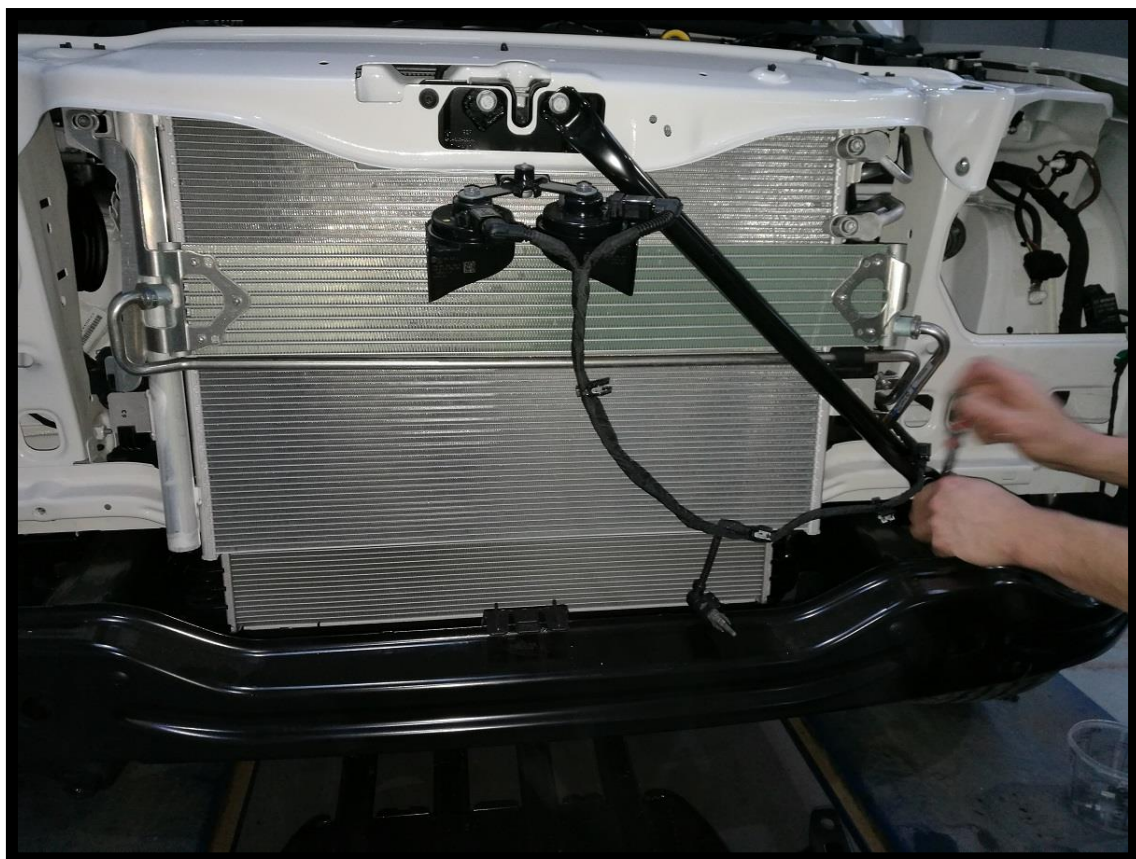

Odkręcić 4 śruby M8 dwóch rurek przednich  
*Unscrew the 4 M8 screws of the two front tubes*





Poluzować rurki boczne od chłodnicy za pomocą klucza TORX  
*Loosen the side tubes from the radiator using the TORX wrench*

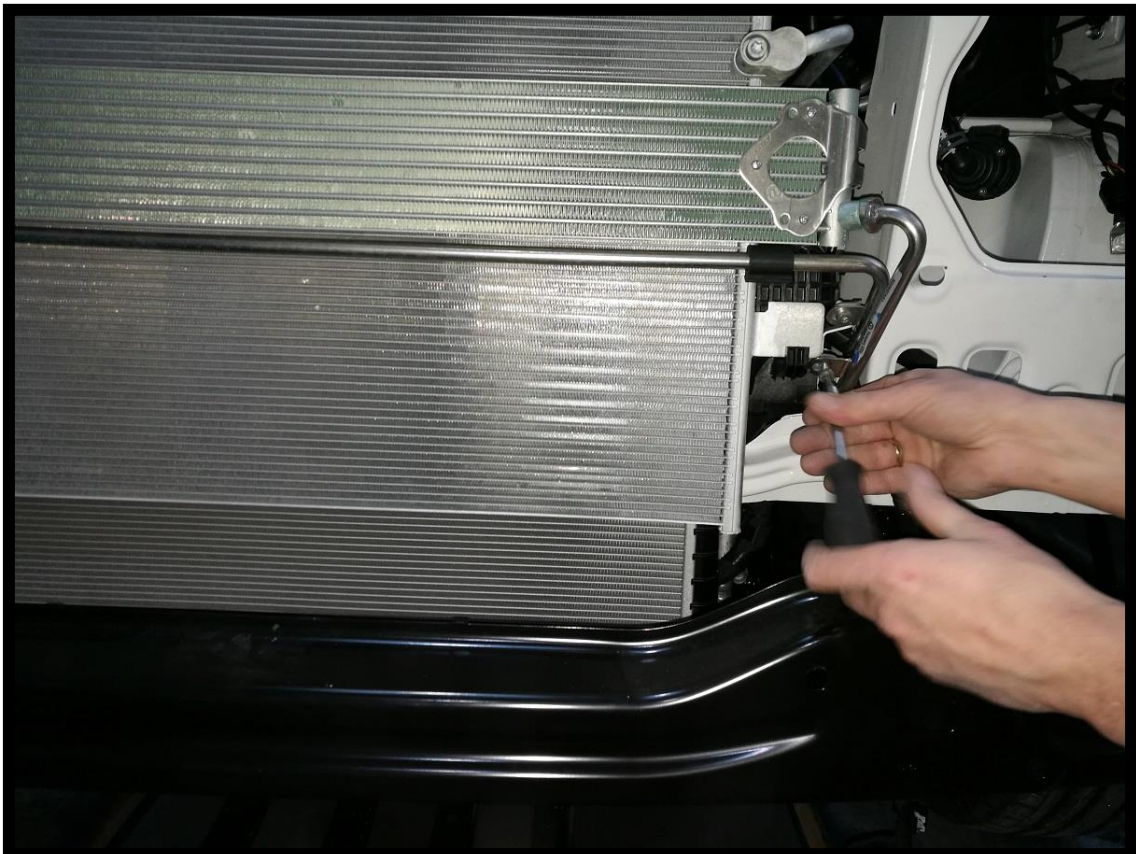





Odkręcić śruby od chłodnicy za pomocą klucza TORX. W tylnej części zdjąć zabezpieczenia.

*Remove the screws from the radiator using the TORX wrench. In the back, remove the protection.*

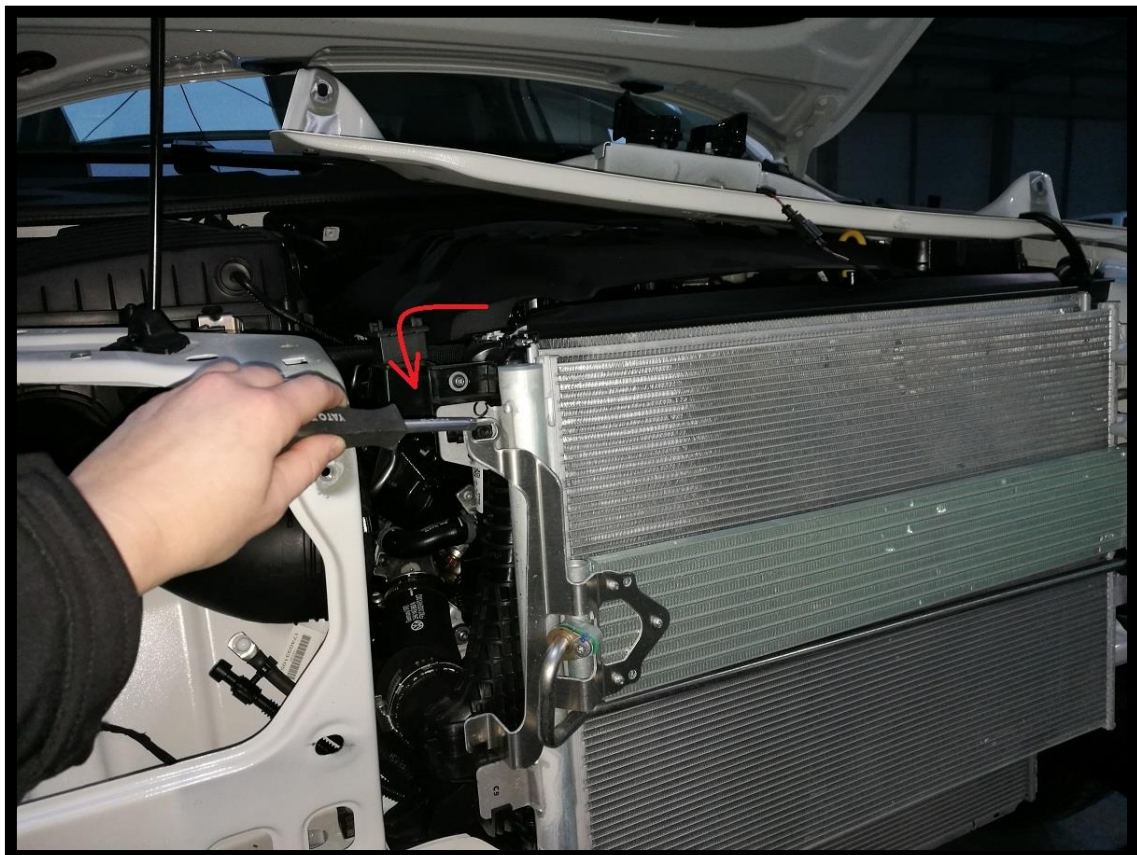



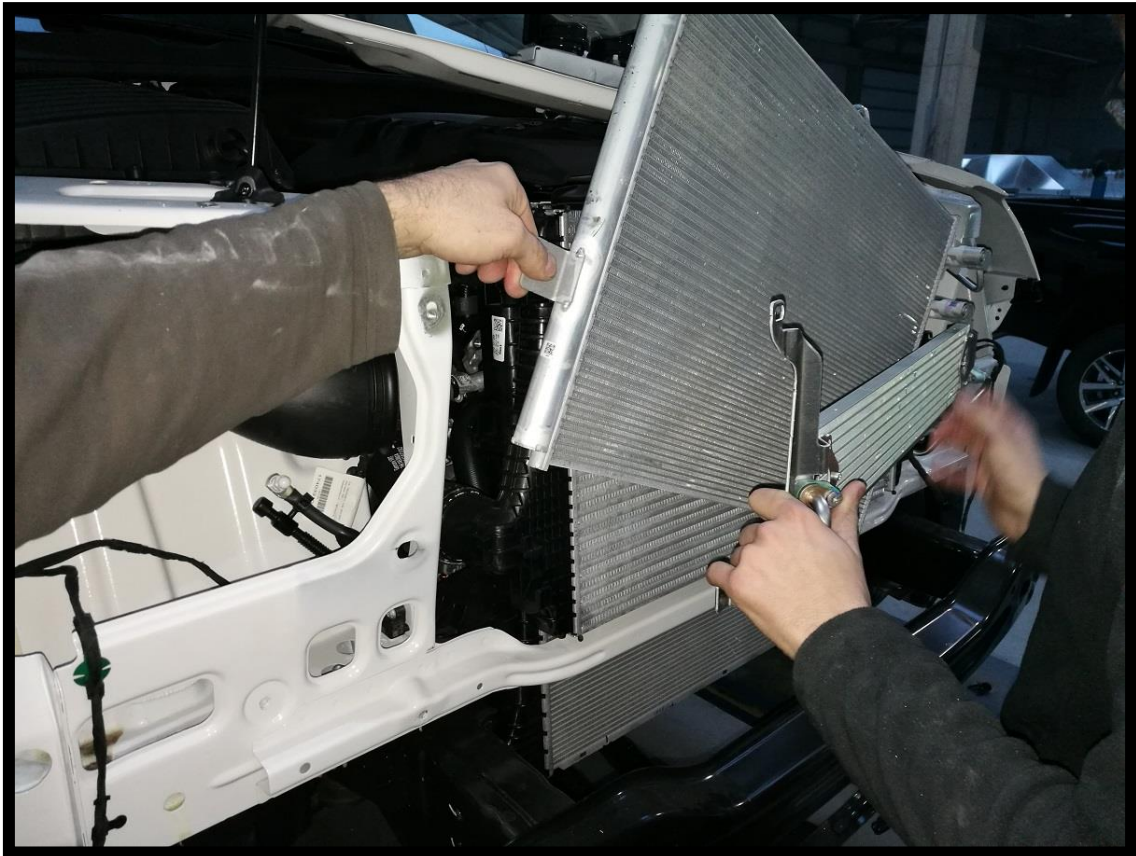

Odchylić dwie przednie chłodnice nie zdejmując ich i włożyć płytę wyciągarki.

Do tego potrzebne są dwie osoby.

*Tilt to the side the two front radiators without removing them and insert the winch plate. For this you need two people.*





*Dla wersji 2,5 / For the version 2,5*

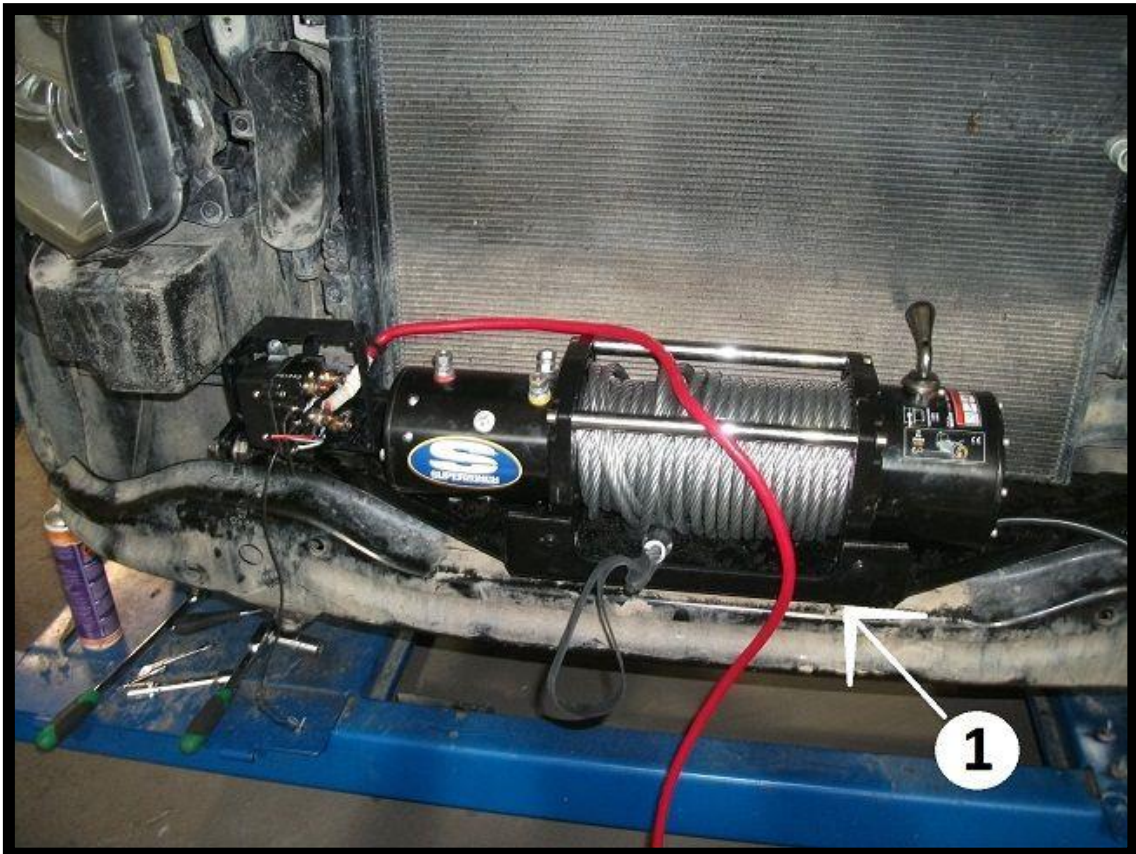



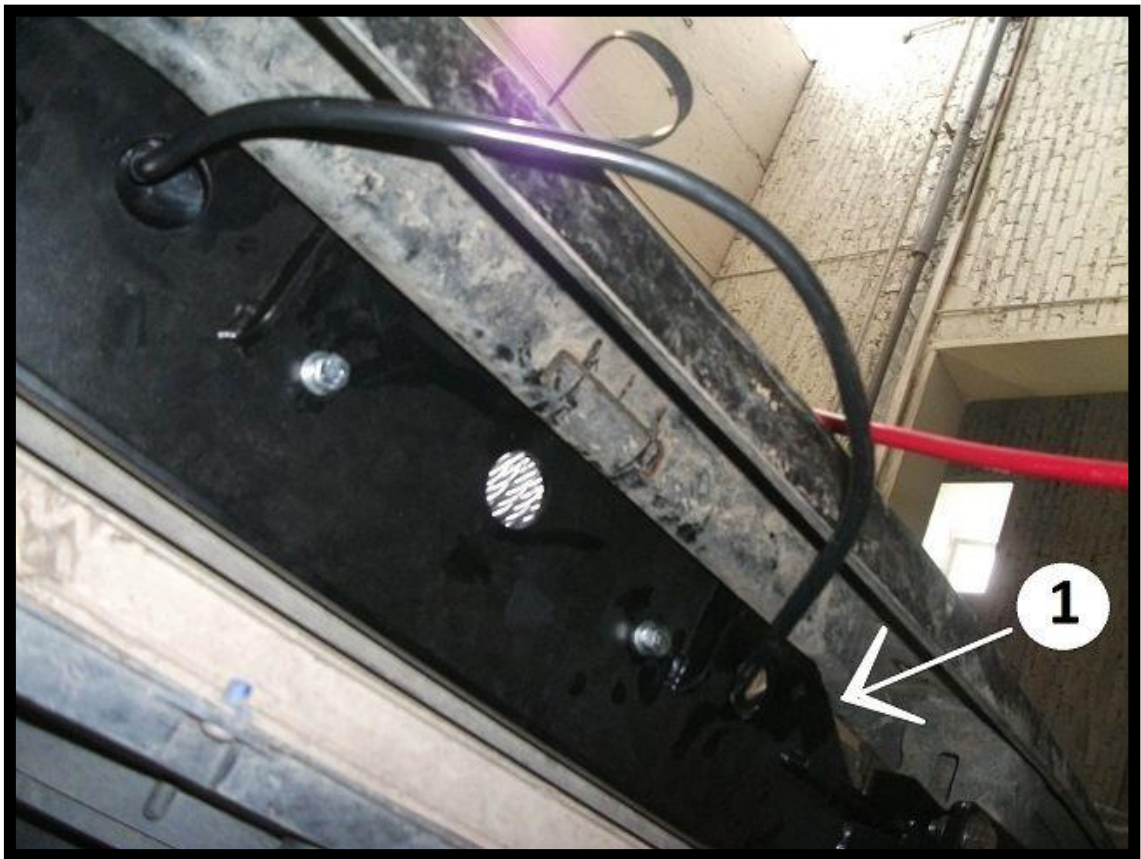



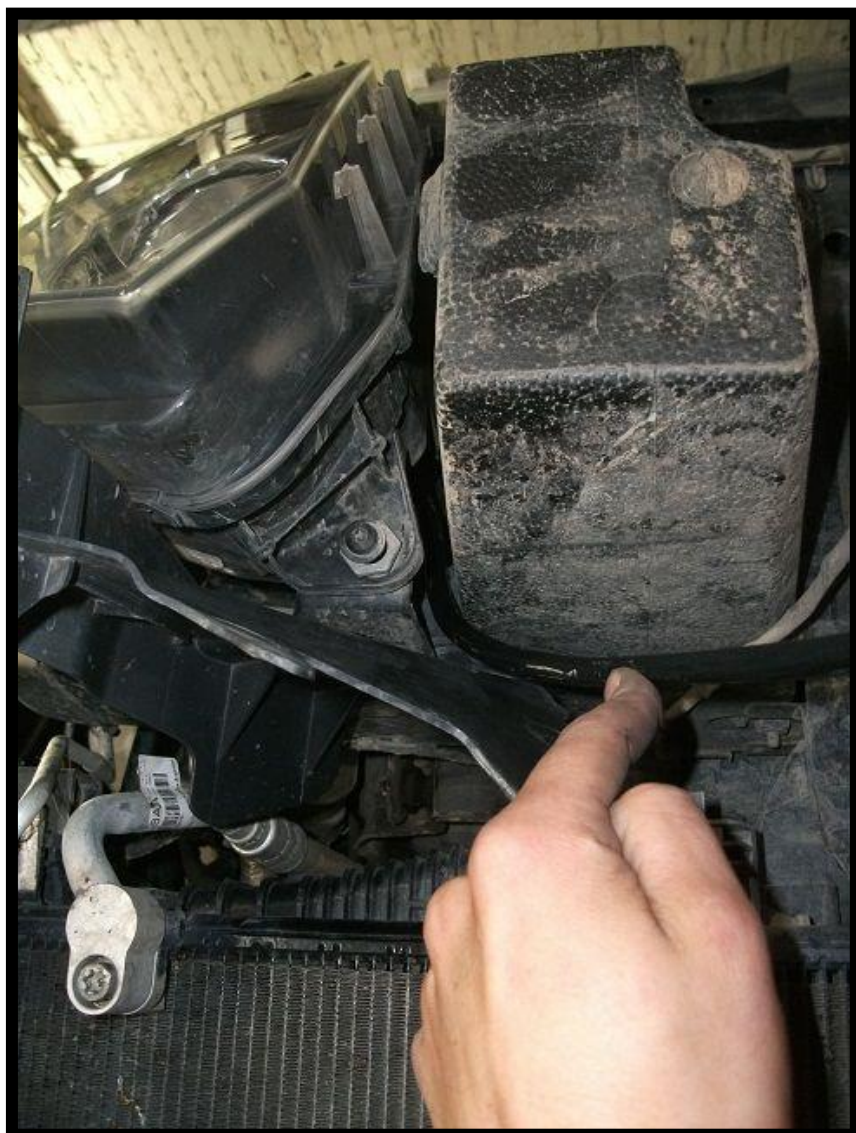
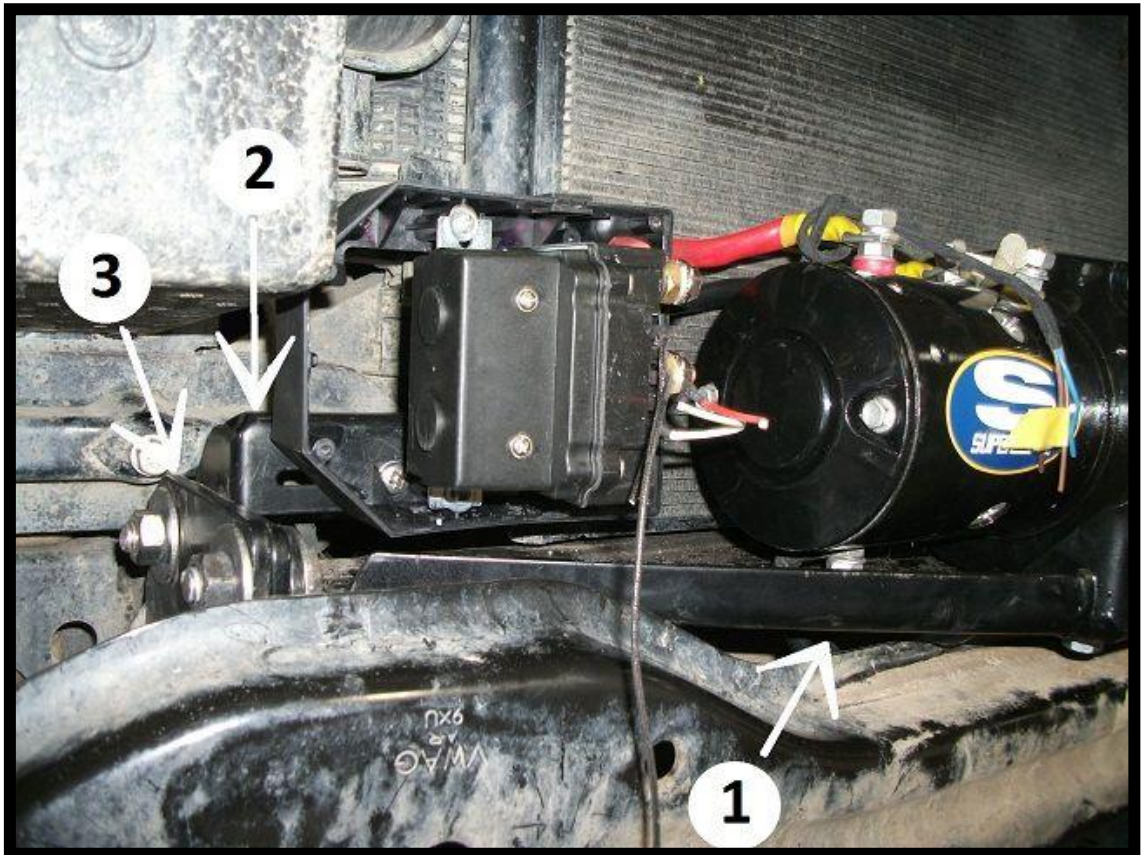



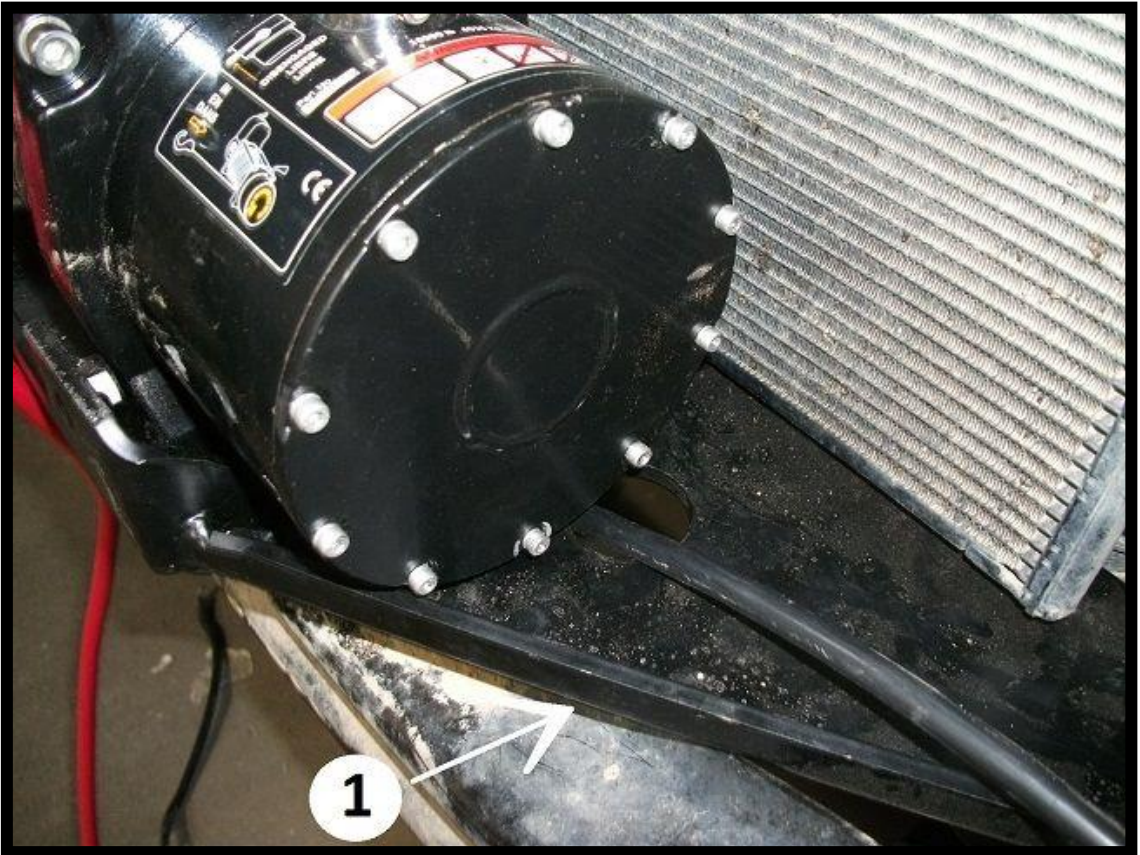







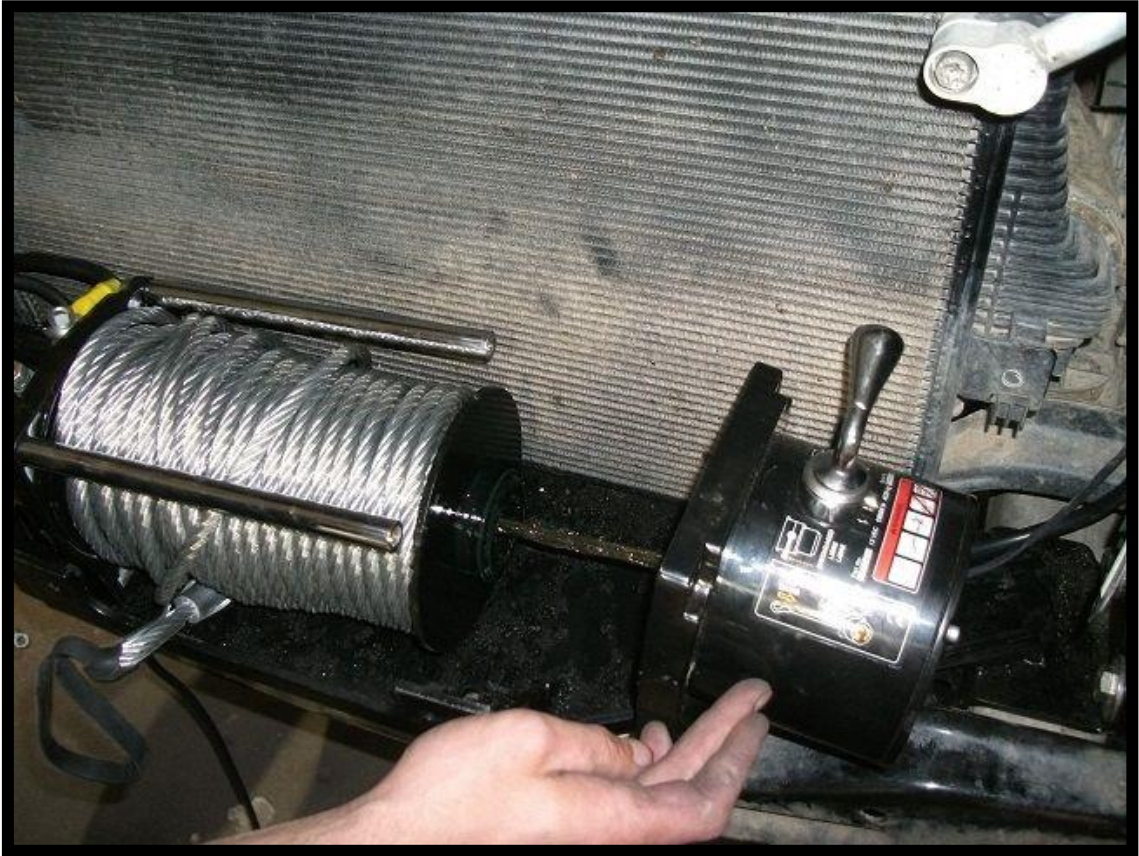







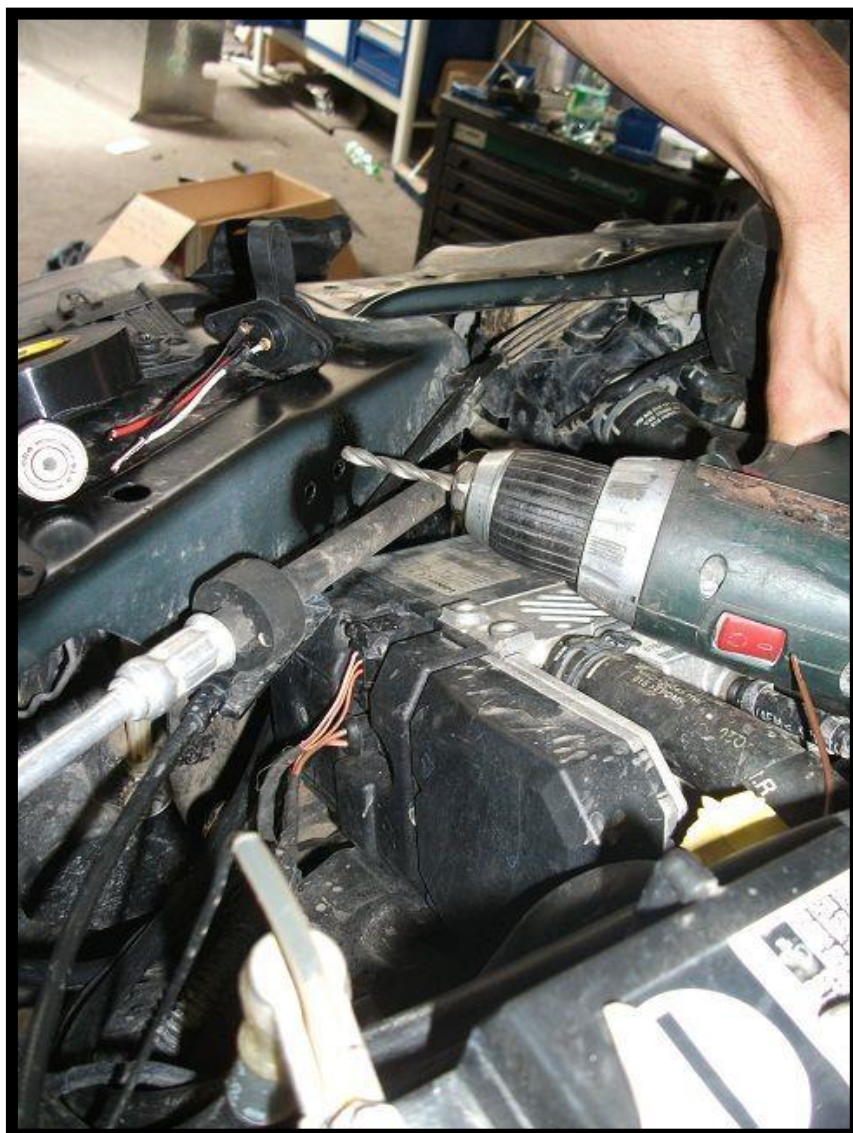
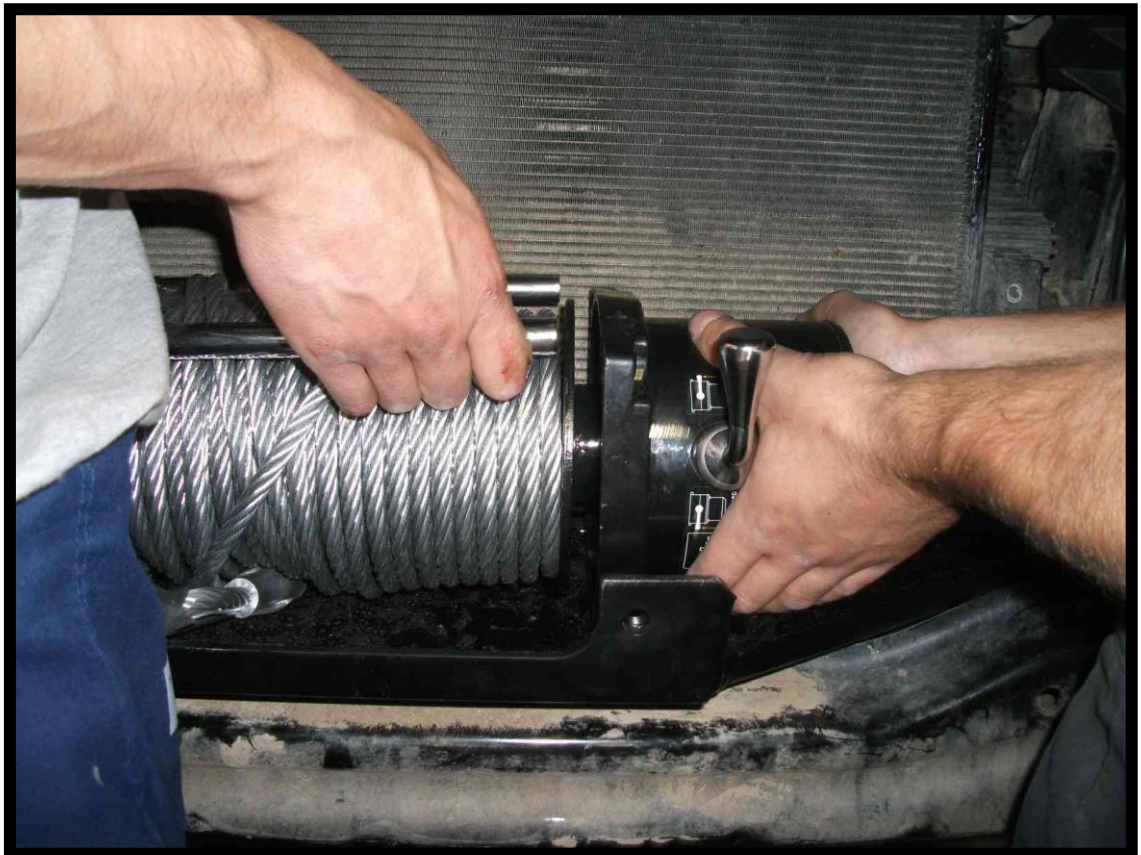







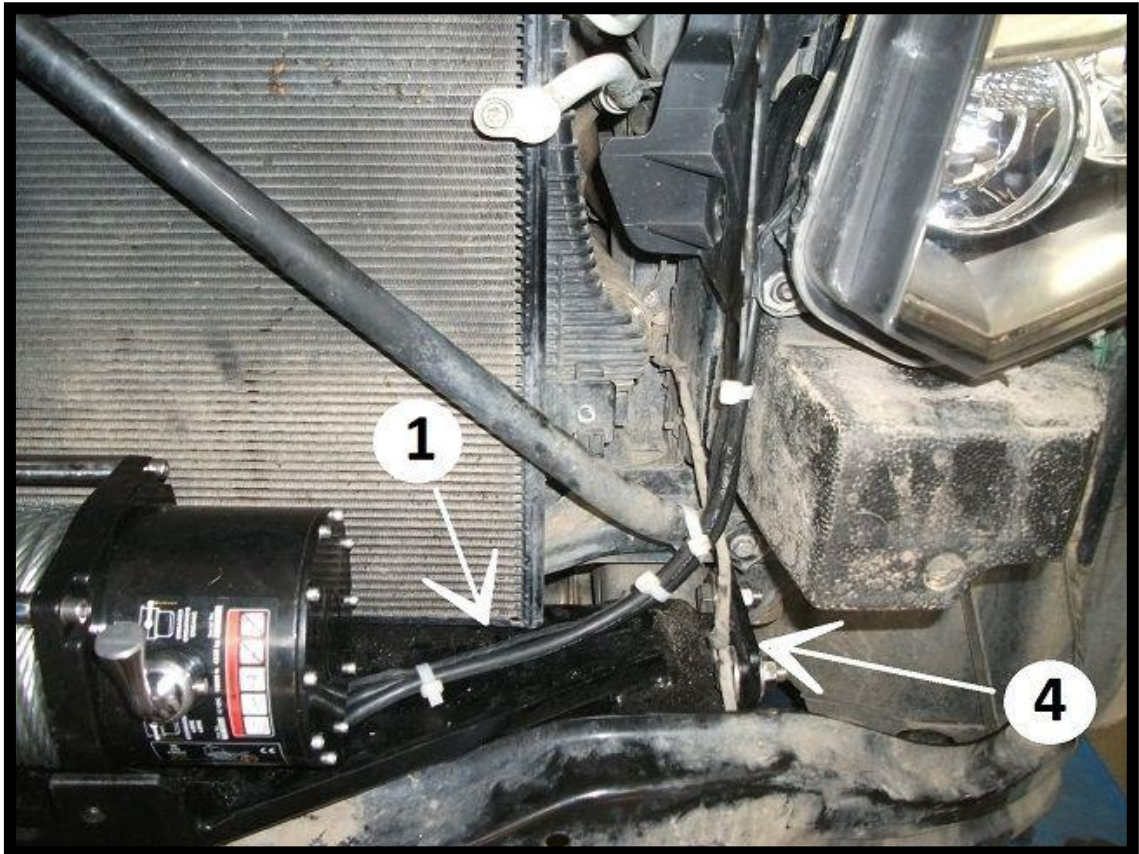

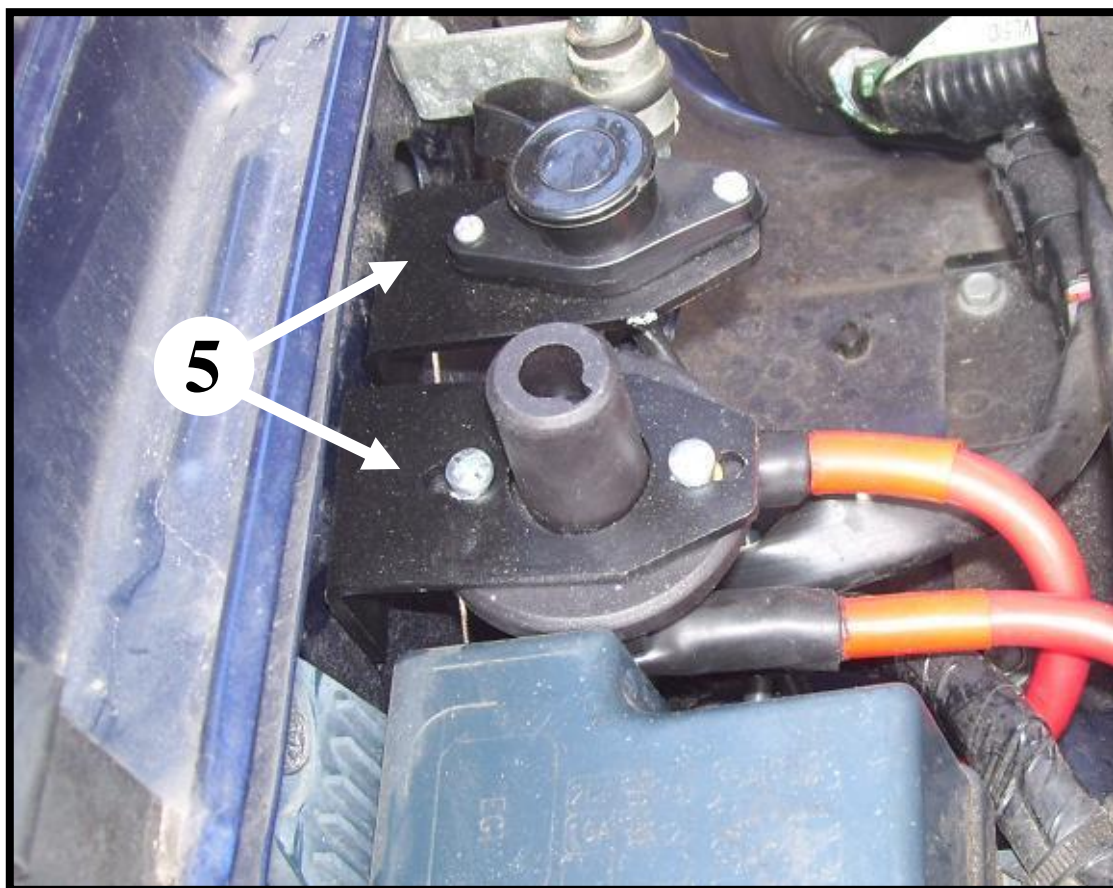

Hebel zabezpieczający (główny wyłącznik prądu)  
montuje się w dowolnym miejscu pod maską.

*Security main breaker is mounted anywhere under the hood.*



# AMAROKV6-PW

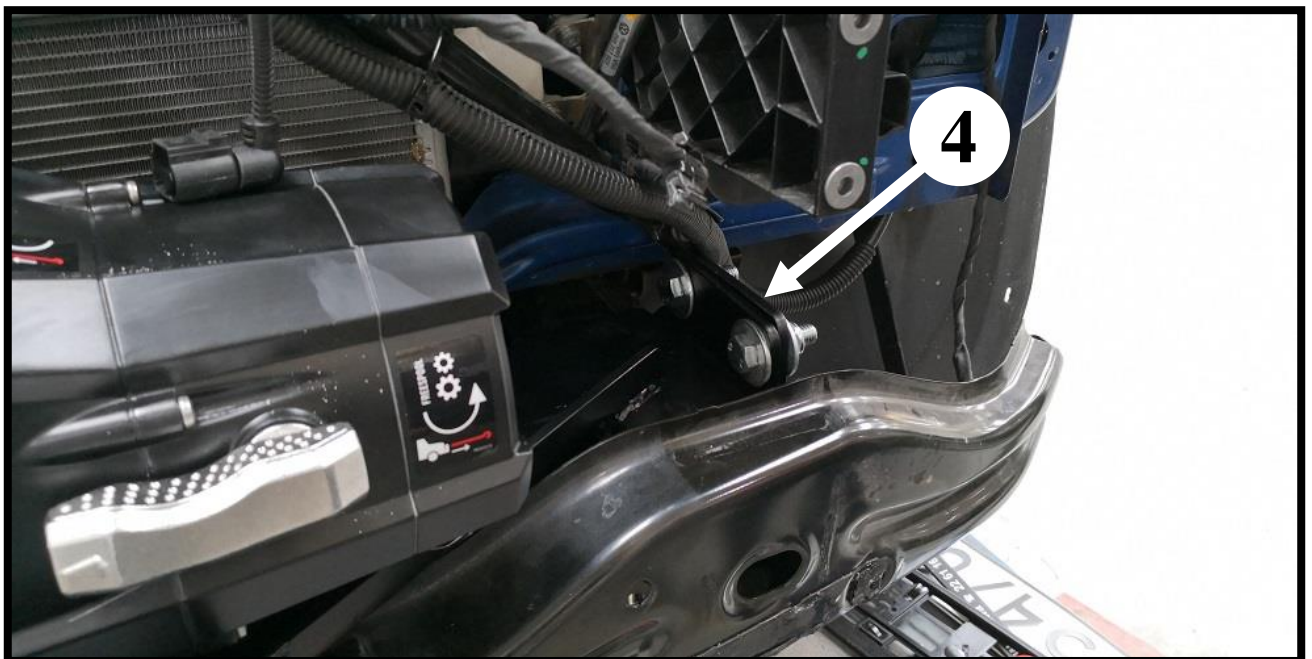
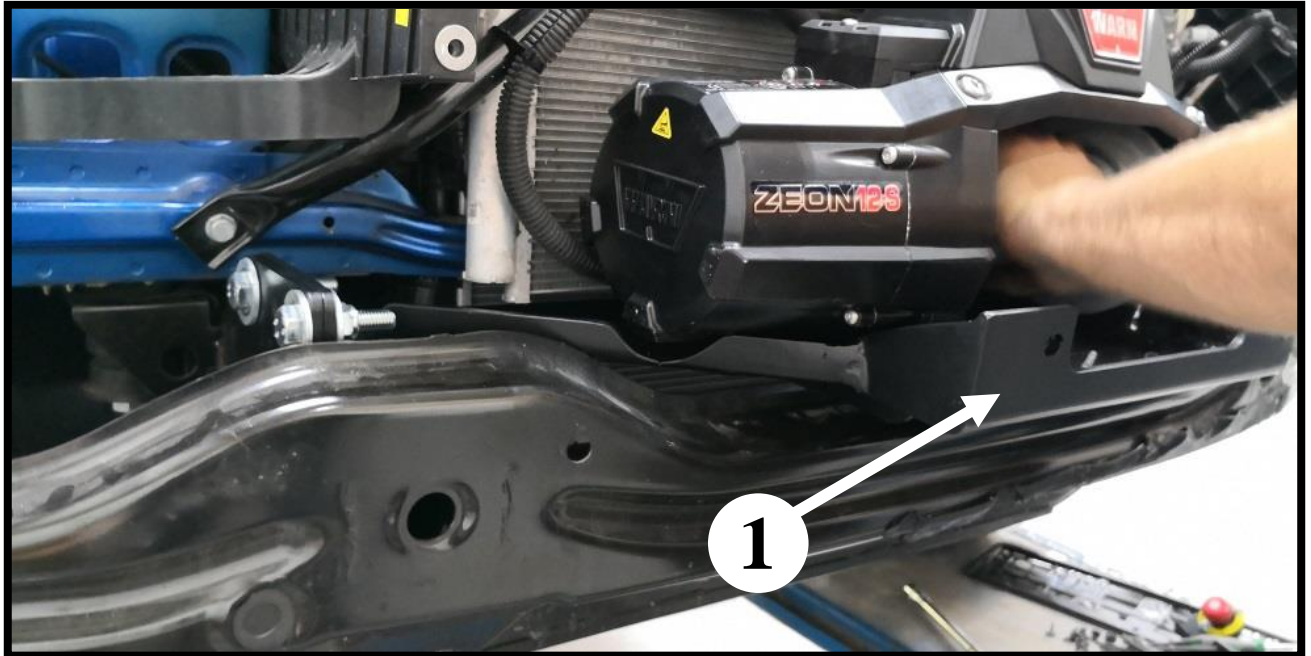

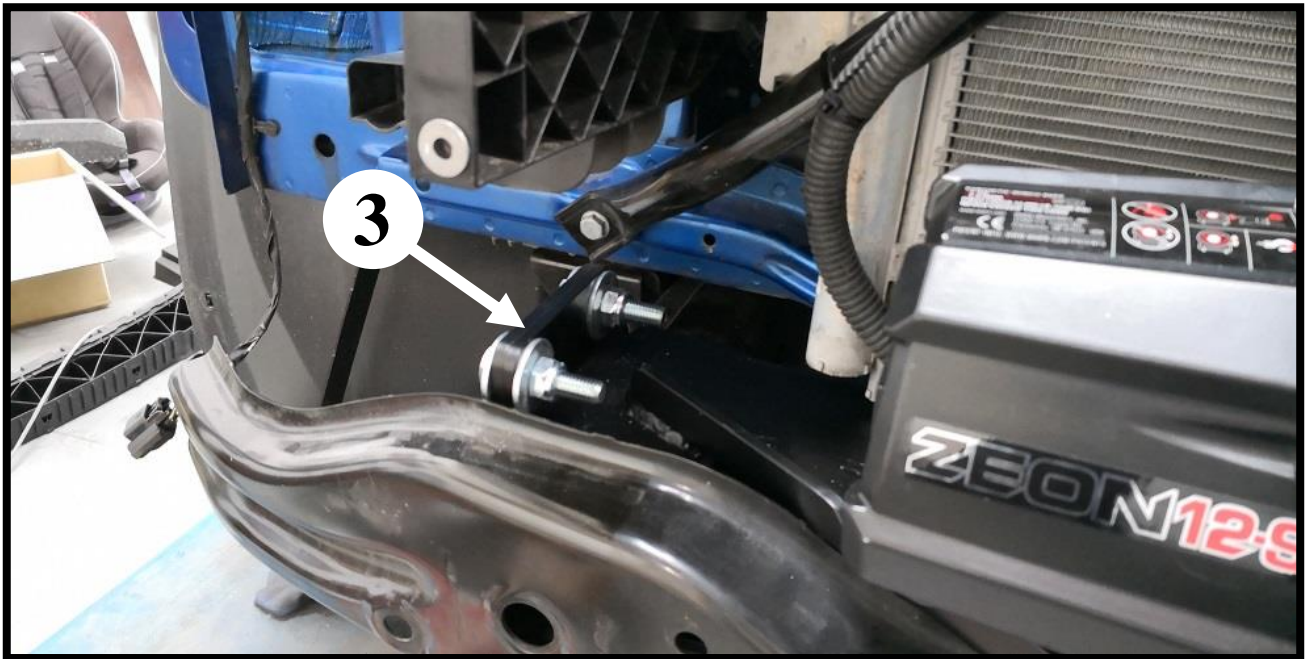





Dopasowanie plastiku + mocowanie kedry.  
*Adaptation of the plastic + fixing of the rubber cover.*



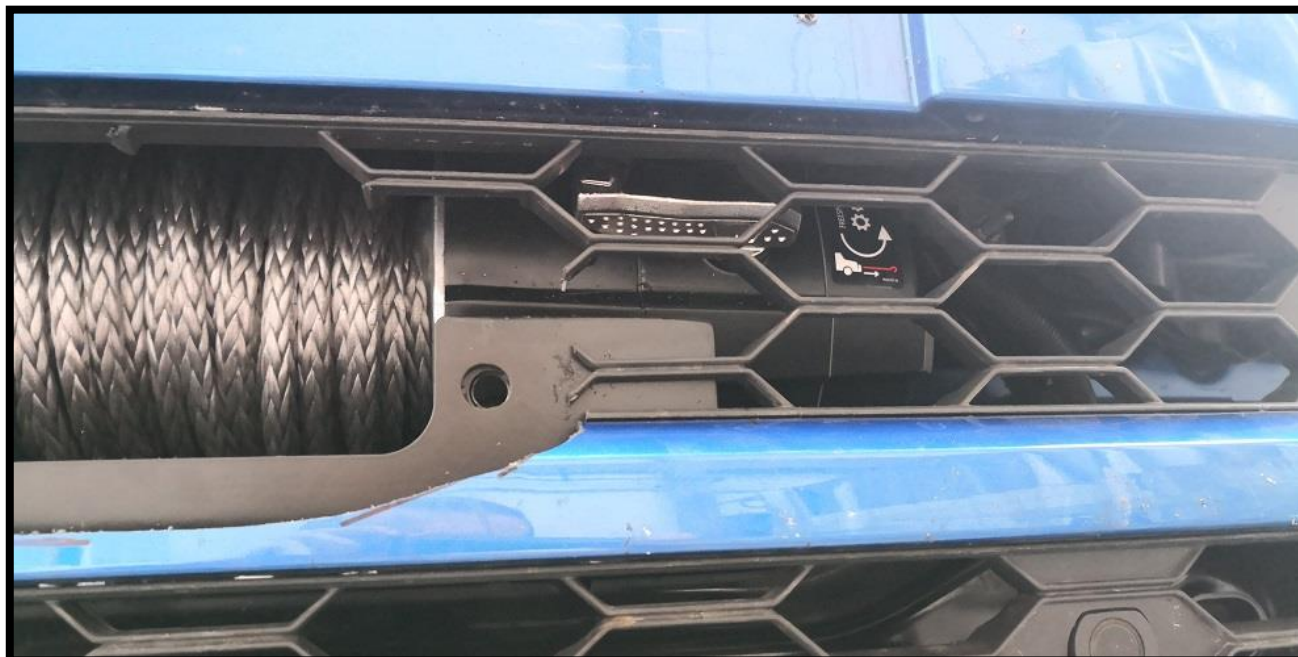

Efekt końcowy po montażu.  
*The final effect after assembly.*





Hebel zabezpieczający (główny wyłącznik prądu)  
montuje się w dowolnym miejscu pod maską.

*Security main breaker is mounted anywhere under the hood.*

