



**STEELER**

**SOKÓŁKA**

***www.steeler.pl***

# **VOLKSWAGEN TOUAREG**



## **INSTRUKCJA MONTAŻU**

(Płyta wciągarki)

## **FITTING INSTRUCTION**

(Winch plate)

## **ИНСТРУКЦИЯ МОНТАЖА**



(Лебедка пластины)

## **MONTAGEANLEITUNG**

(Winch Platte)

# **TOUAREG-PW**

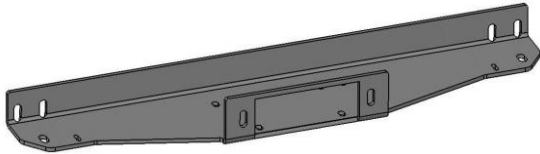
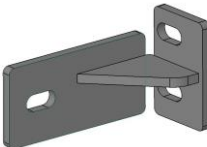
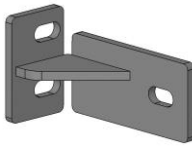
**Wykaz elementów:**  
**Specification of full assembly:**  
**Список элементов тюнинга:**  
**Liste der Elemente:**

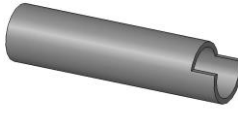
<p>1. Płyta wciągarki (szt. 1) Winch plate (1 pc.) Лебедка пластины (шт.1) Winch Platte (st.1)</p>	
<p>2. Zamocowanie prawe I (szt. 1) Right attachment I (1 pc.) Крепление правое I (шт.1) Montage rechts I (st.1)</p>	
<p>3. Zamocowanie lewe I (szt. 1) Left attachment I (1 pc.) Крепление левое I (шт.1) Montage links I (st.1)</p>	
<p>4. Dystans I (szt.4) Distance I (4 pcs.) Ø22x2 L=20 Расстояние I (шт.4) Abstand I (St.4)</p>	
<p>5. Dystans II (szt.2) Distance II (2 pcs.) Ø22x2 L=88 Расстояние II (шт.2) Abstand II (St.2)</p>	

**Wykaz elementów łącznych:**  
**Connecting components:**  
**Список соединительных элементов:**  
**Die Auflistung der Elemente:**

<p>Śruby (szt.) Screws (pcs.) Болты (шт.) Schrauben (st.)</p>	<p>M10x50 – (4) M12x140 – (2)</p>	<p>Nakrętki (szt.) Nuts (pcs.) Гайки (шт.) Muttern (st.)</p>	<p>M12 - (2)</p>
<p>Podkładki (szt.) Washers (pcs.) Шайбы (шт.) Unterlegscheiben(st.)</p>	<p>Ø 11 – (4)-XL Ø 13 – (4)-XL</p>	<p style="text-align: center;">17 19 <b>46 Nm</b></p> 	

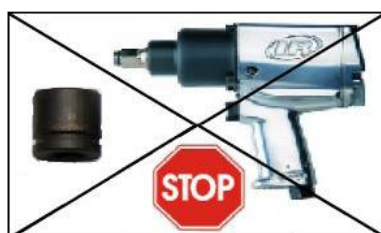

Czas montażu  
Fitting time  
Время монтажа  
Montagezeit



**UWAGA: Folię usunąć dopiero po montażu!**  
**ATTENTION: Foil remove after fitting!**  
**ВНИМАНИЕ: Целлофан снять только после завершения монтажа!**  
**HINWEIS: Die Folie soll erst nach der Montage entfernt werden!**

**Montaż / Fitting / Монтаж / Montage**  
TOUAREG-PW

	Śruby (szt.) Screws (pcs.) Болты (шт.) Schrauben (st.)	Podkładki (szt.) Washers (pcs.) Шайбы (шт.) Unterlegscheiben (st.)	Nakrętki (szt.) Nuts (pcs.) Гайки (шт.) Muttern (st.)
<b>A</b>	M10x50	Ø11	-----
<b>B</b>	M12x140	Ø13(x2)	-----

19,5kg

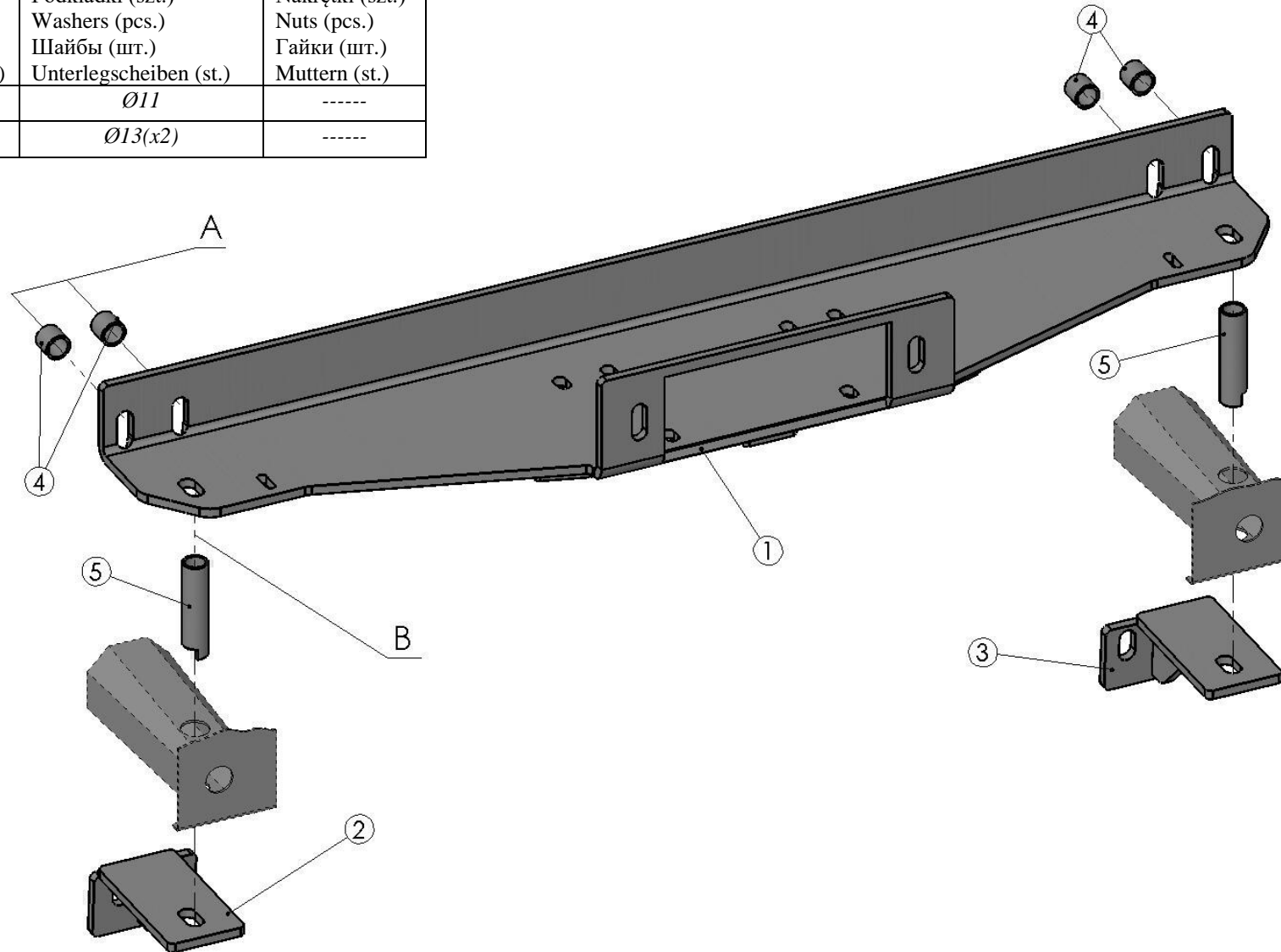

*Montaż (zdjęcia) / Fitting (pictures) / Монтаж (фотографии)  
/ Montage (Fotos)*

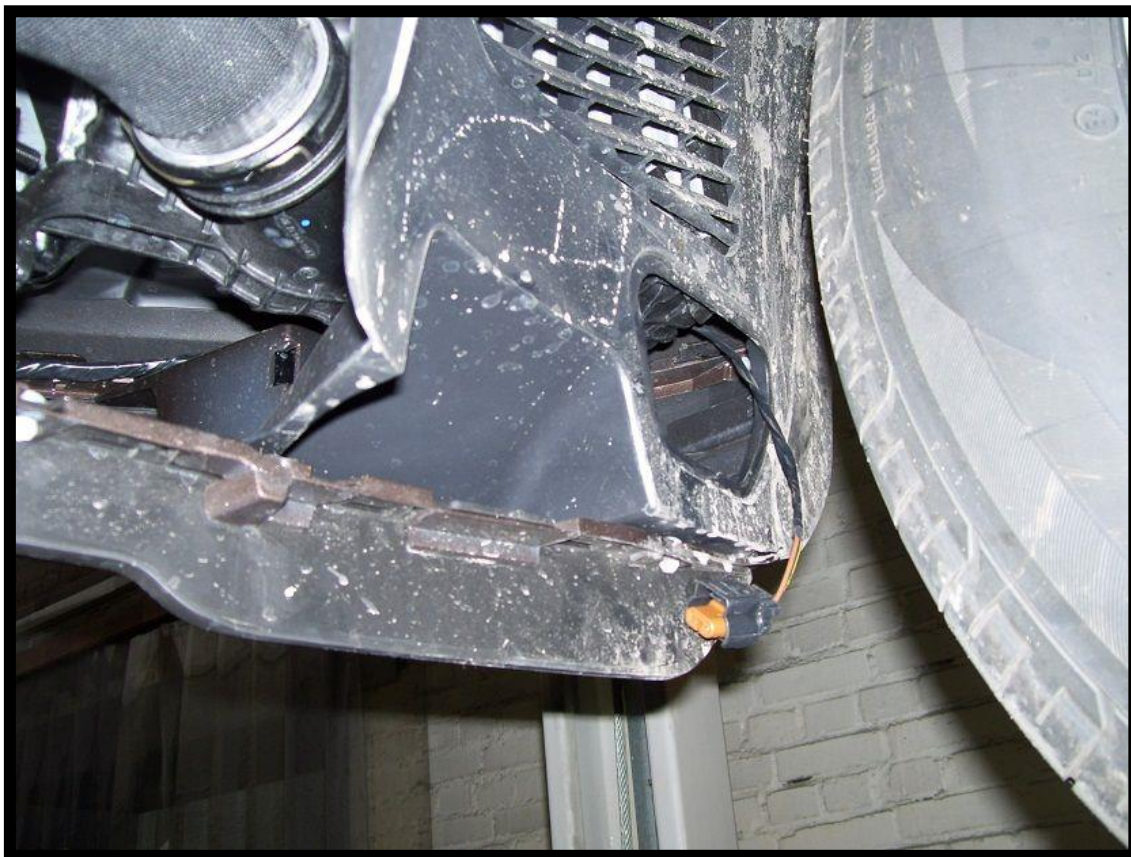

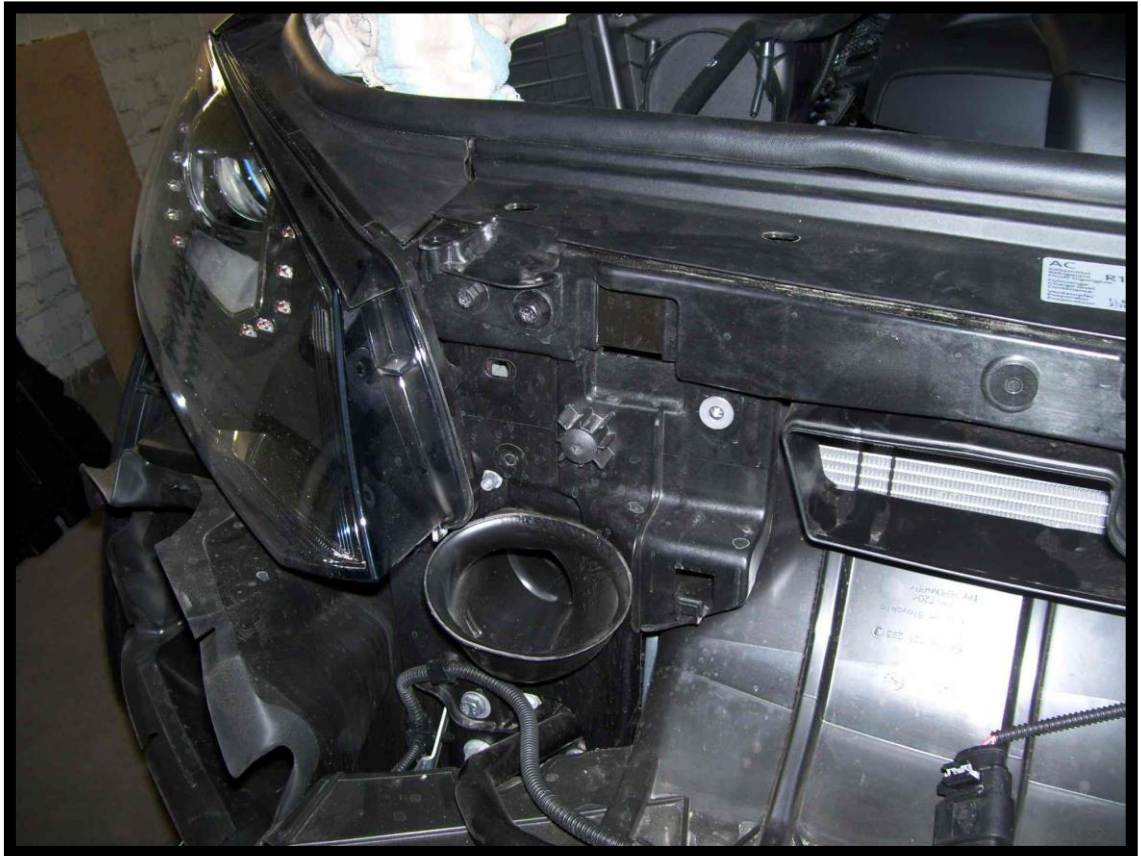
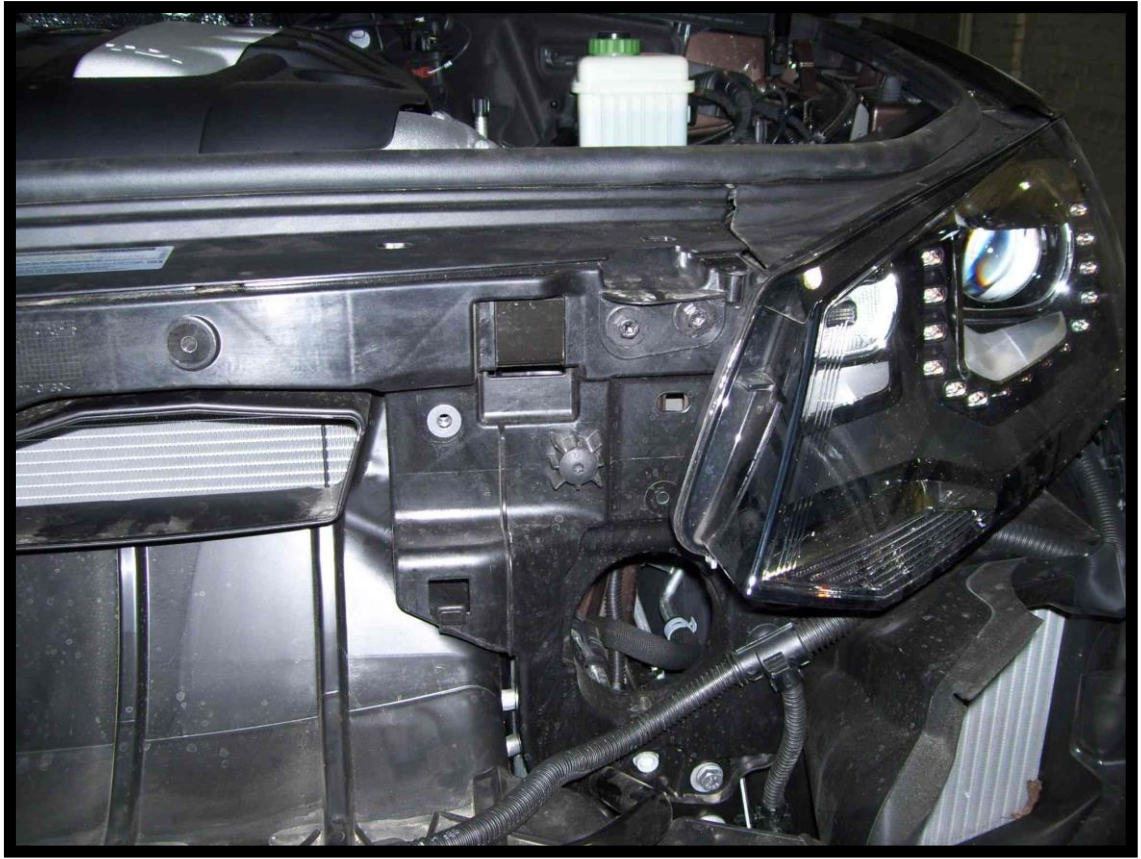



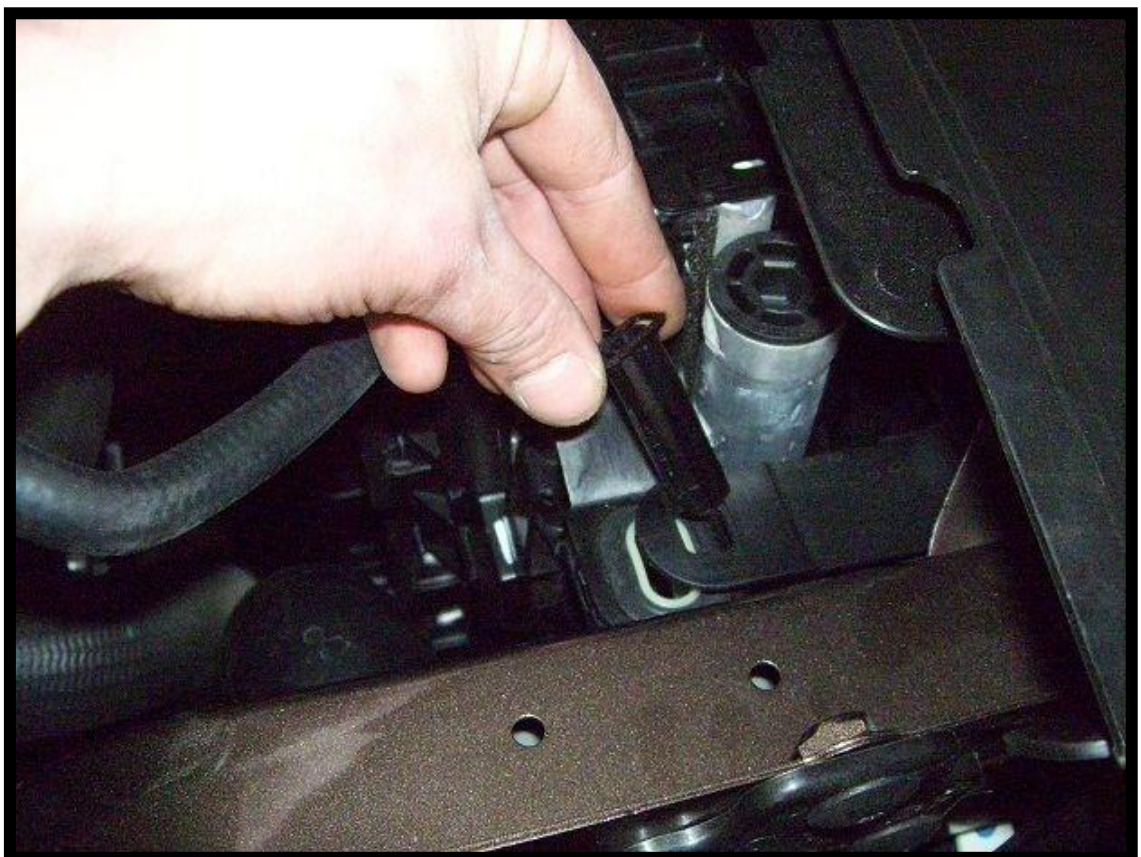





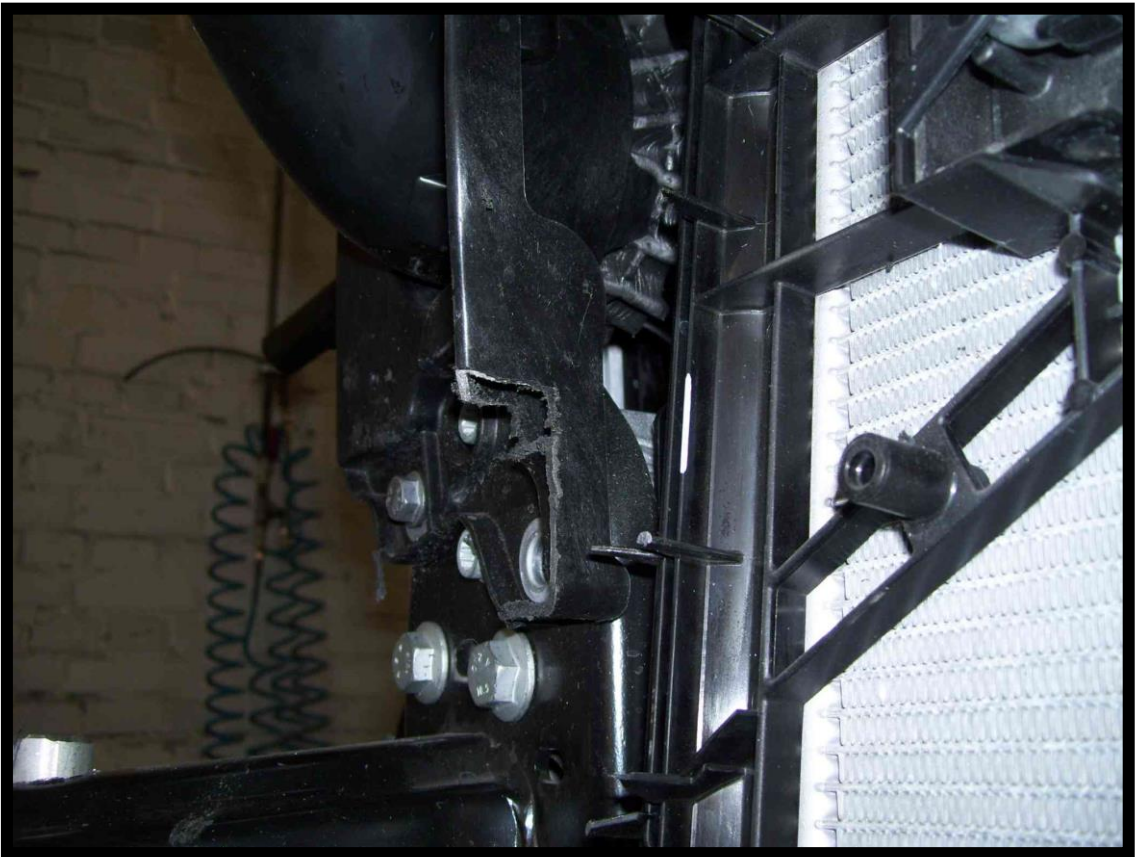

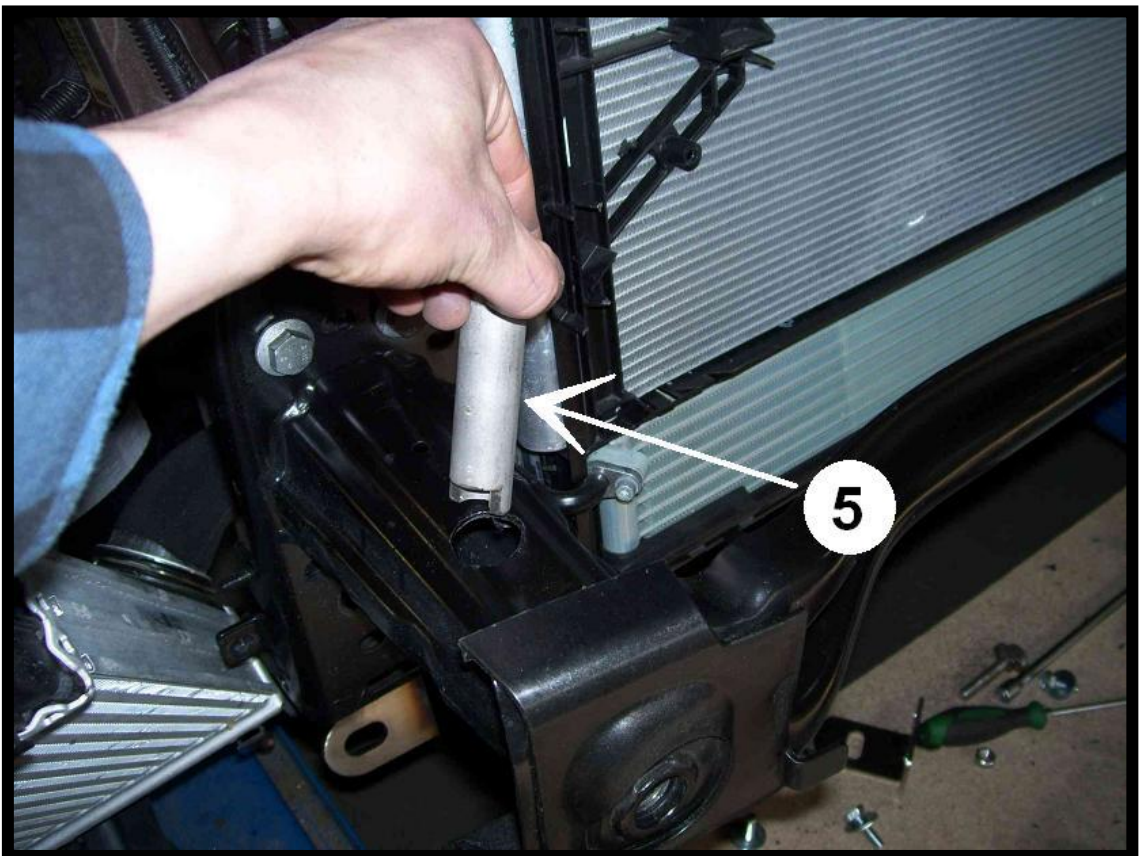
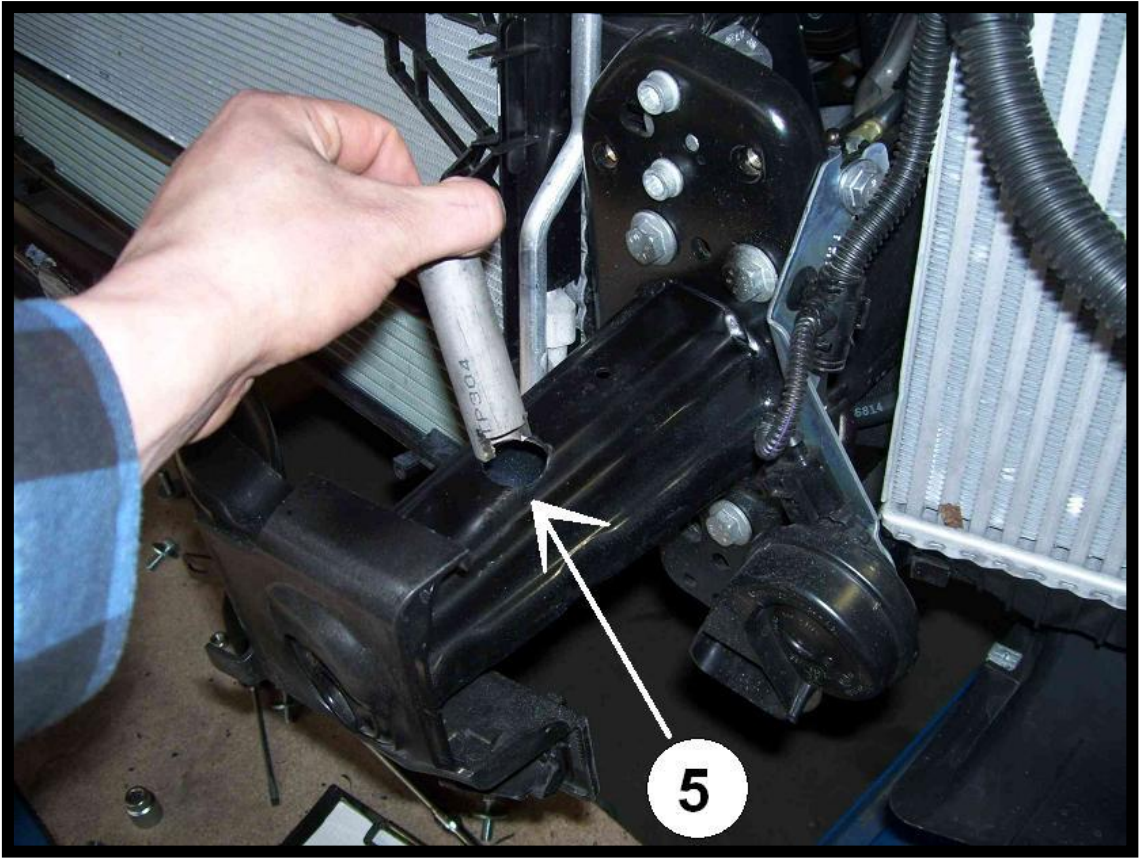

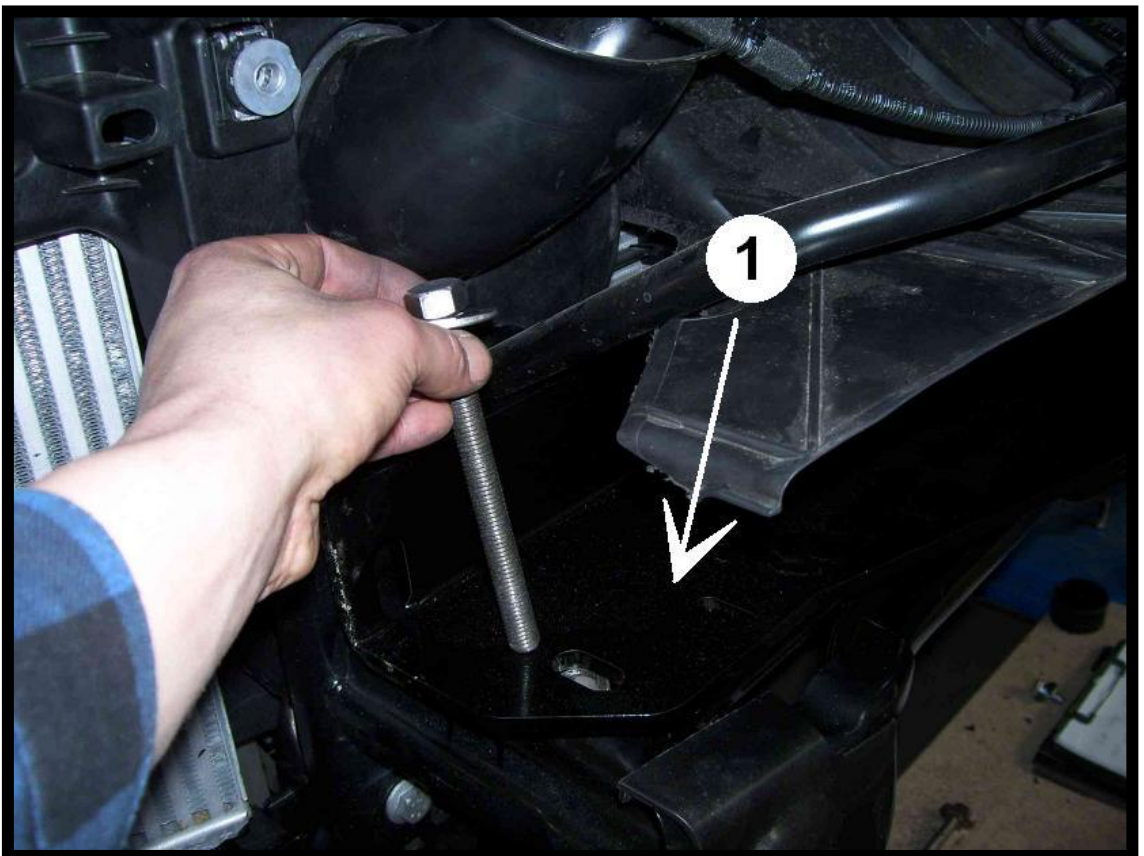
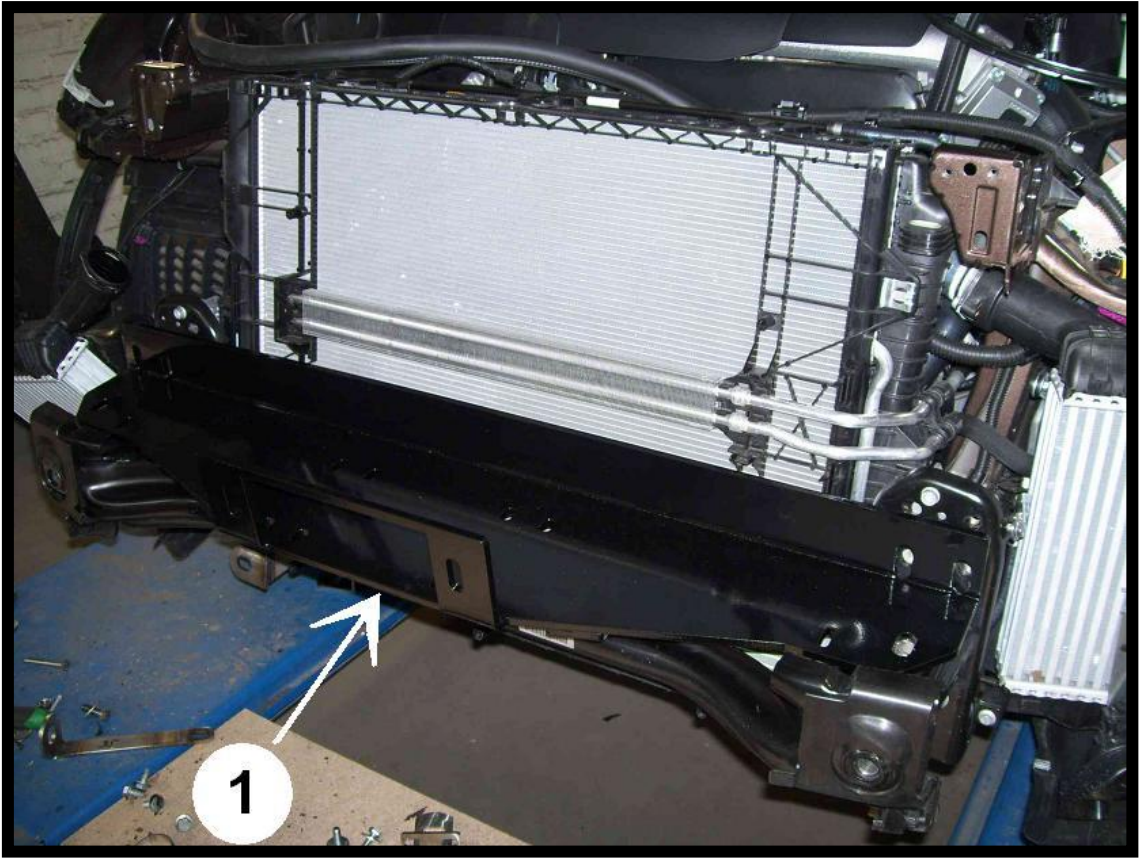

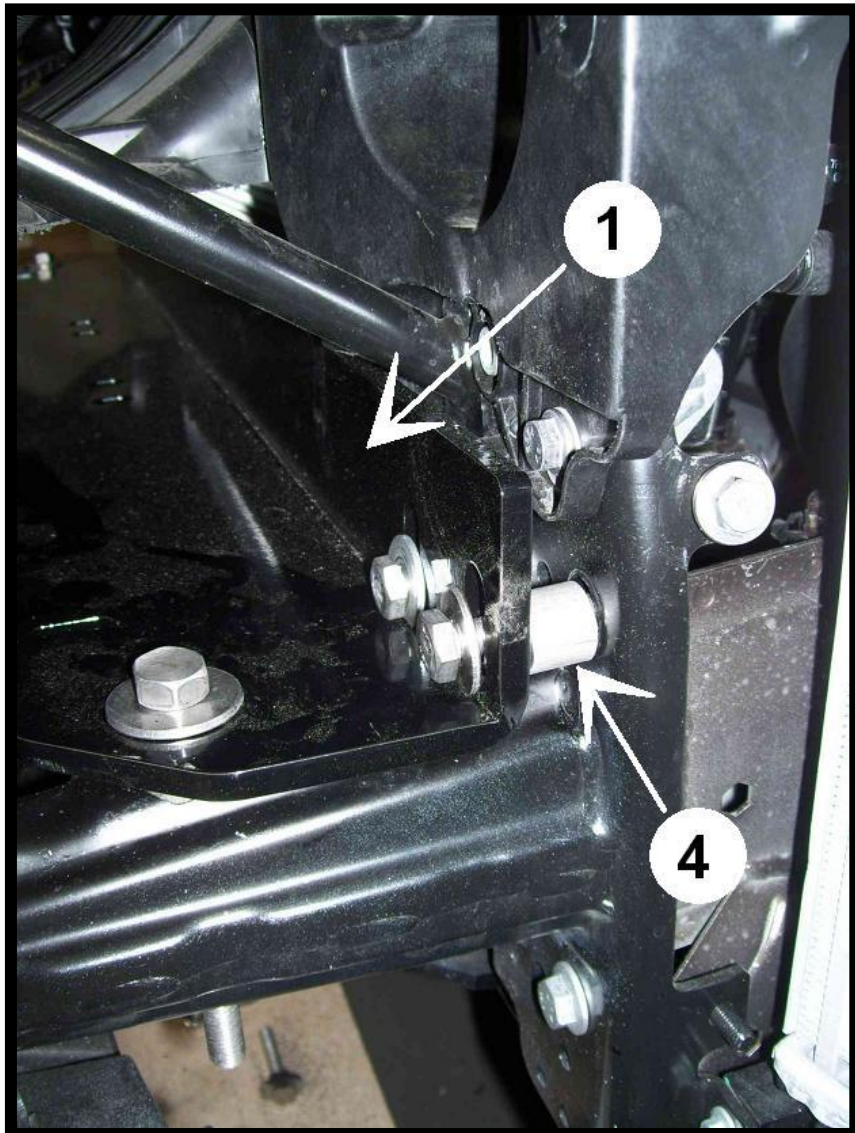
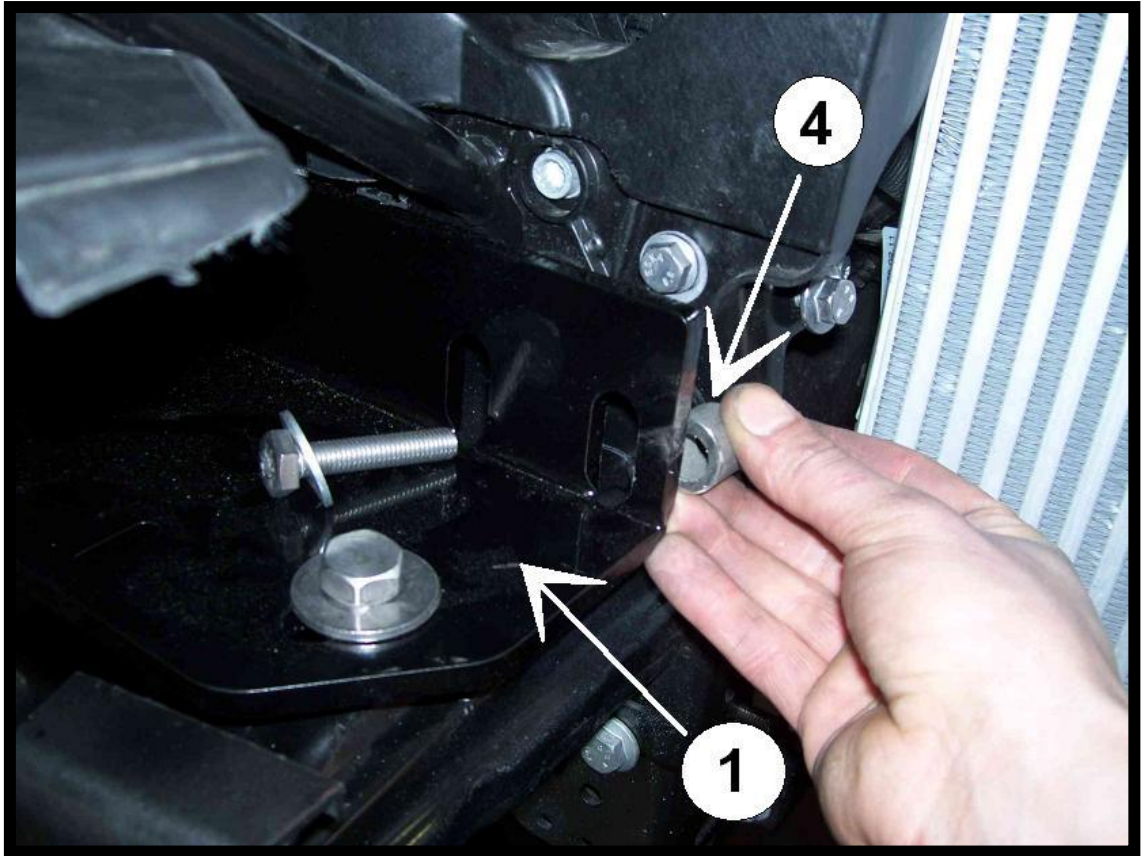

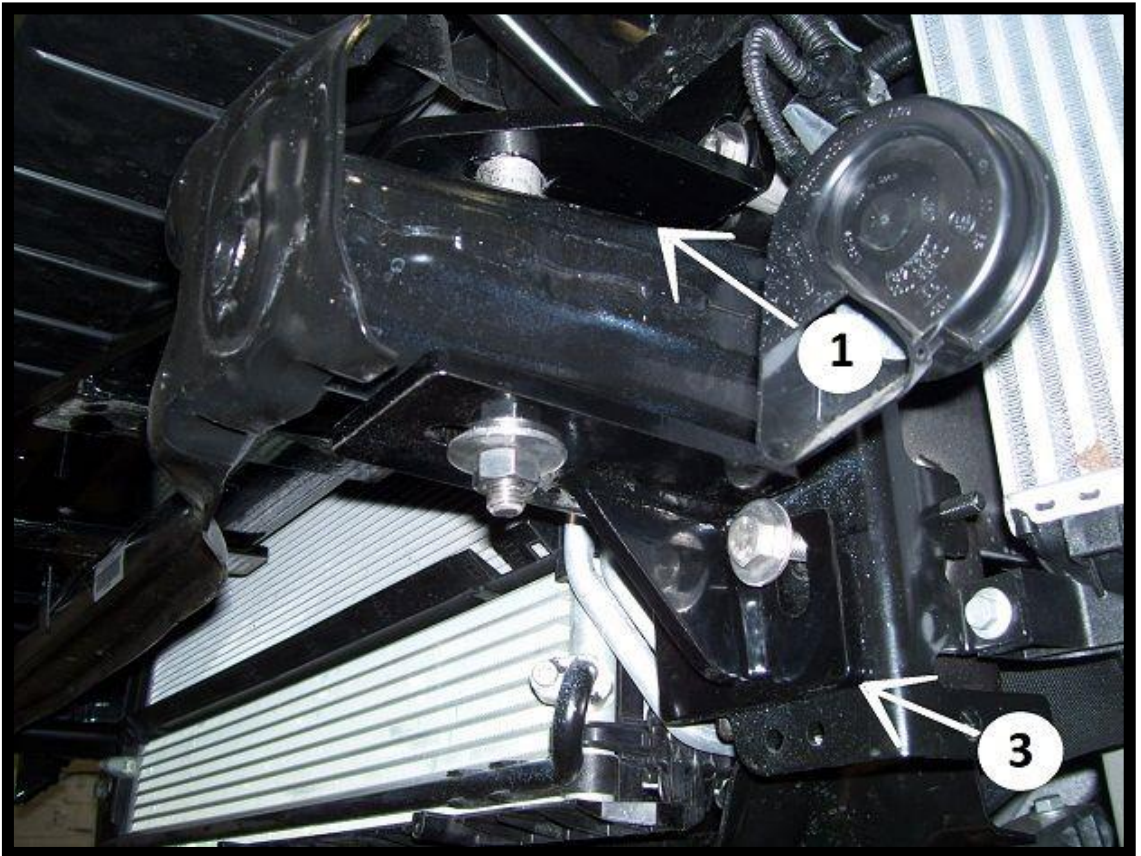
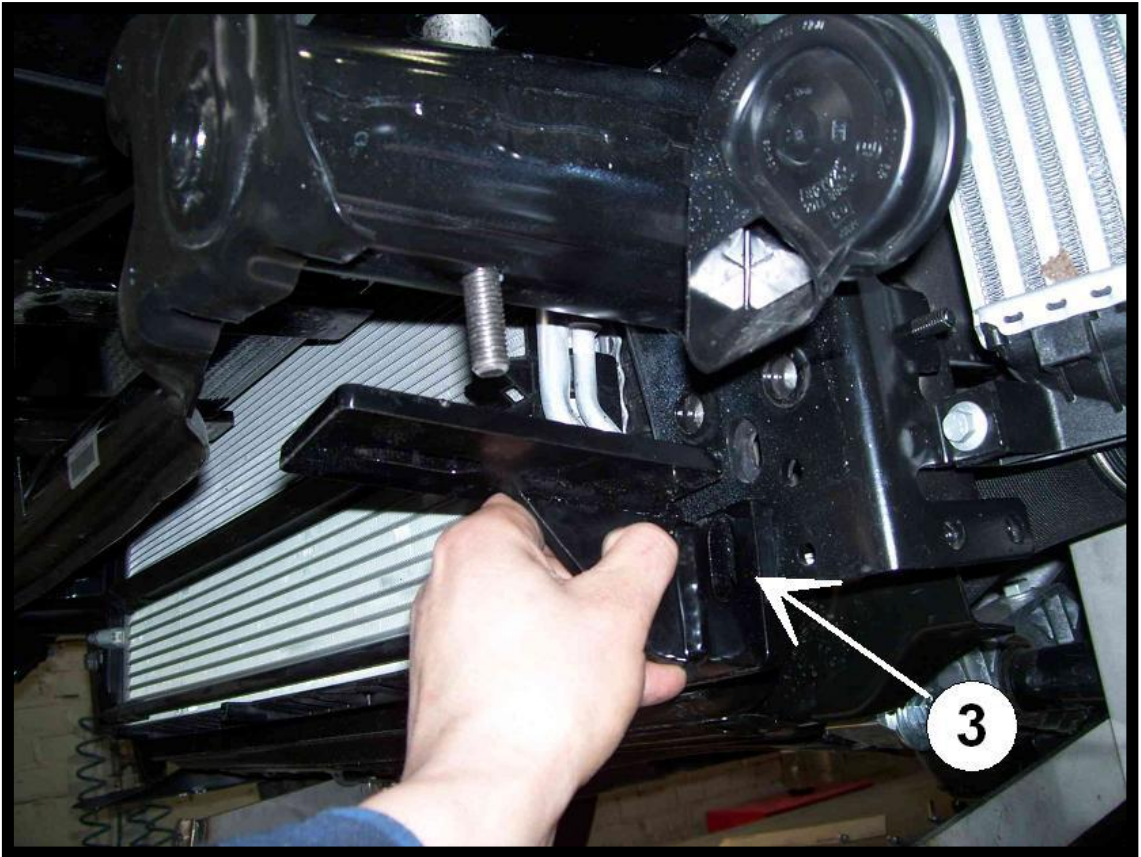

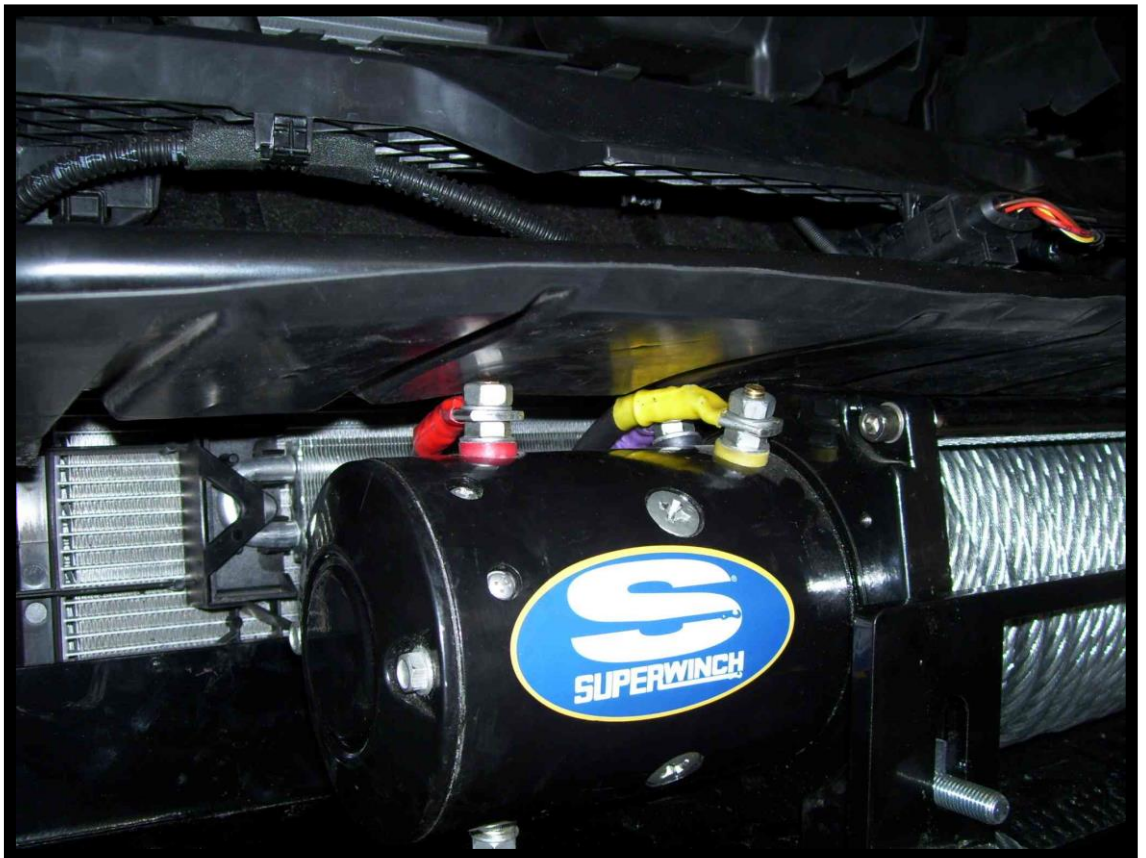
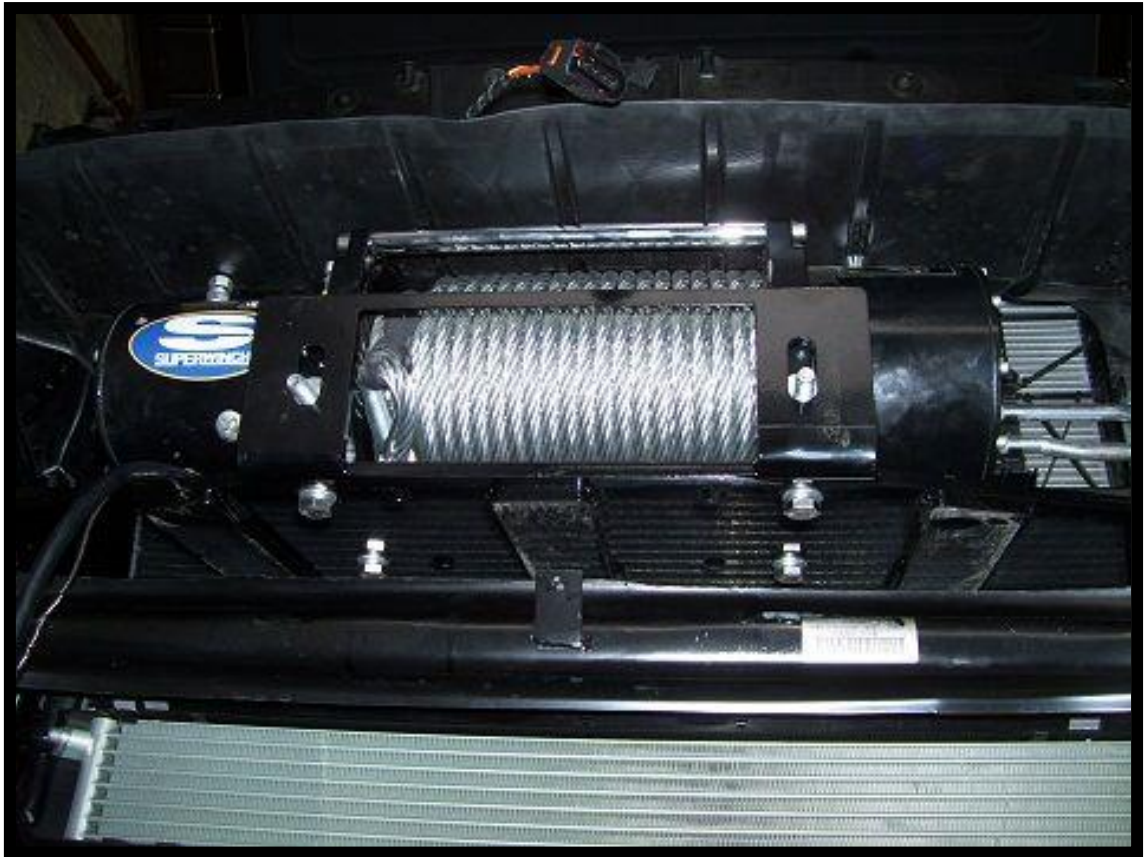



Hebel zabezpieczający (główny wyłącznik prądu)  
montuje się w dowolnym miejscu pod maską.

*Security main breaker is mounted anywhere under the hood.*