



**STEELER**

**SOKÓŁKA**

***www.steeler.pl***

## **FORD RANGER 2012; 2016**



### **INSTRUKCJA MONTAŻU**

(Płyta wyciągarki)

### **FITTING INSTRUCTION**

(Winch plate)

### **ИНСТРУКЦИЯ МОНТАЖА**

(Лебедка пластины)

### **MONTAGEANLEITUNG**



(Winch Platte)

**R12-PW / R16-PW**

**R12-PW-R / R16-PW-R**

**R16-PW-RADAR**

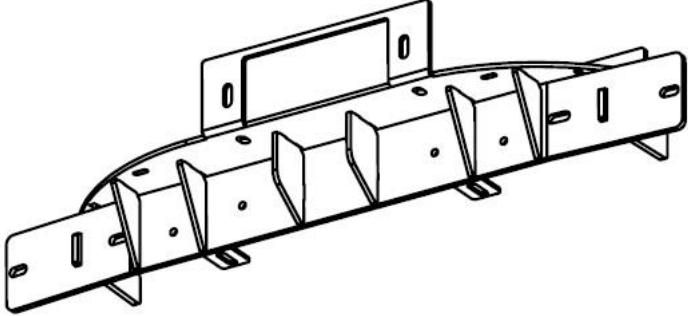
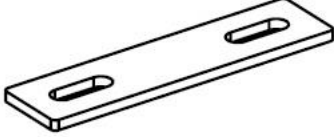
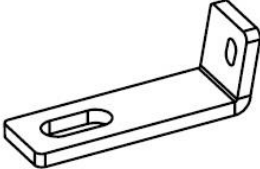
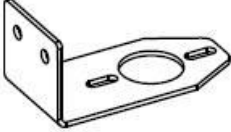
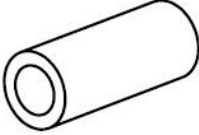
**Wykaz elementów:**  
**Specification of full assembly:**  
**Список элементов тюнинга:**  
**Liste der Elemente:**

<p>1. Płyta wyciągarki (szt. 1)  Winch plate (1 pcs.)  Лебедка пластины (шт.1)  Winch Platte (st.1)</p>	
<p>2. Zamocowanie I (szt. 2)  Attachment I (2 pcs.)  Крепление I (шт.2)  Montage I (st.2)</p>	
<p>3. Zamocowanie II (szt. 1)  Attachment II (1 pcs.)  Крепление II (шт.1)  Montage II (st.1)</p>	
<p>4. Zamocowanie III (szt. 2)  Attachment III (2 pcs.)  Крепление III (шт.2)  Montage III (st.2)</p>	
<p>5. Dystans I (szt.2)  Distance I (2 pcs.) Ø 22x4 L=55  Расстояние I (шт.2)  Distanzring I (st.2)</p>	
<p>6. Dystans II (szt.1)  Distance II (1 pcs.)  Расстояние II (шт.1)  Distanzring II (st.1)</p>	



Czas montażu  
Fitting time  
Время монтажа  
Montagezeit



**4,5h**

M6 - 11 Nm	M8 - 25 Nm	M10 - 50 Nm	M12 - 87 Nm
------------	------------	-------------	-------------

***UWAGA: Folię usunąć dopiero po montażu!***

***ATTENTION: Foil remove after fitting!***

***ВНИМАНИЕ: Целлофан снять только после завершения монтажа!***

***HINWEIS: Die Folie soll erst nach der Montage entfernt werden***

**Wykaz elementów łącznych:**  
**Connecting components:**  
**Список соединительных элементов:**  
**Die Auflistung der Elemente:**

**R12-PW / R16-PW**

Śruby (szt.) Screws (pcs.) Болты (шт.) Schrauben (st.)	M6x40 – (4) M10x30 – (2) M10x40 – (4) M12x35 – (2)	Nakrętki (szt.) Nuts (pcs.) Гайки (шт.) Muttern (st.)	M6 - (4) M10 - (2)
Podkładki (szt.) Washers (pcs.) Шайбы (шт.) Unterlegscheiben(st.)	Ø6 – (8)–XL Ø6 – (4)–SPR Ø10 – (8)–XL Ø10 – (6)–SPR Ø12 – (2)–XL Ø12 – (2)–SPR		

**R12-PW-R / R16-PW-R**

(Orurowanie przednie / Front bulbar / Кенгурин / Frontschutzbügel)

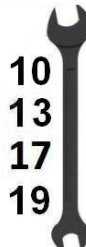
Śruby (szt.) Screws (pcs.) Болты (шт.) Schrauben (st.)	M6x40 – (4) M8x80 – (2) M10x30 – (2) M10x40 – (4) M12x35 – (2)	Nakrętki (szt.) Nuts (pcs.) Гайки (шт.) Muttern (st.)	M6 - (4) M8 - (2) M10 - (2)
Podkładki (szt.) Washers (pcs.) Шайбы (шт.) Unterlegscheiben(st.)	Ø6 – (8)–XL Ø6 – (4)–SPR Ø8 – (4)–XL Ø8 – (2)–SPR Ø10 – (8)–XL Ø10 – (6)–SPR Ø12 – (2)–XL Ø12 – (2)–SPR		

**R16-PW-RADAR**

Śruby (szt.) Screws (pcs.) Болты (шт.) Schrauben (st.)	M6x30 – (1) M6x40 – (5) M10x30 – (2) M10x40 – (3) M10x50 – (1) M12x35 – (2)	Nakrętki (szt.) Nuts (pcs.) Гайки (шт.) Muttern (st.)	M6 - (4) M6 - (2) (sam./self-locking) M10 - (2)
Podkładki (szt.) Washers (pcs.) Шайбы (шт.) Unterlegscheiben(st.)	Ø6 – (12)–XL Ø6 – (6)–SPR Ø10 – (8)–XL Ø10 – (6)–SPR Ø12 – (2)–XL Ø12 – (2)–SPR		

**Montaż / Fitting / Монтаж / Montage**  
R12-PW / R16-PW

	Śruby (szt.) Screws (pcs.) Болты (шт.) Schrauben (st.)	Podkładki (szt.) Washers (pcs.) Шайбы (шт.) Unterlegscheiben (st.)	Nakrętki (szt.) Nuts (pcs.) Гайки (шт.) Muttern (st.)
<b>C</b>	M6x40	Ø6-XL(x2); Ø6-SPR	M6
<b>E</b>	M10x30	Ø10-XL(x2); Ø10-SPR	M10
<b>F</b>	M10x40	Ø10-XL; Ø10-SPR	-----
<b>G</b>	M12x35	Ø12-XL; Ø12-SPR	-----

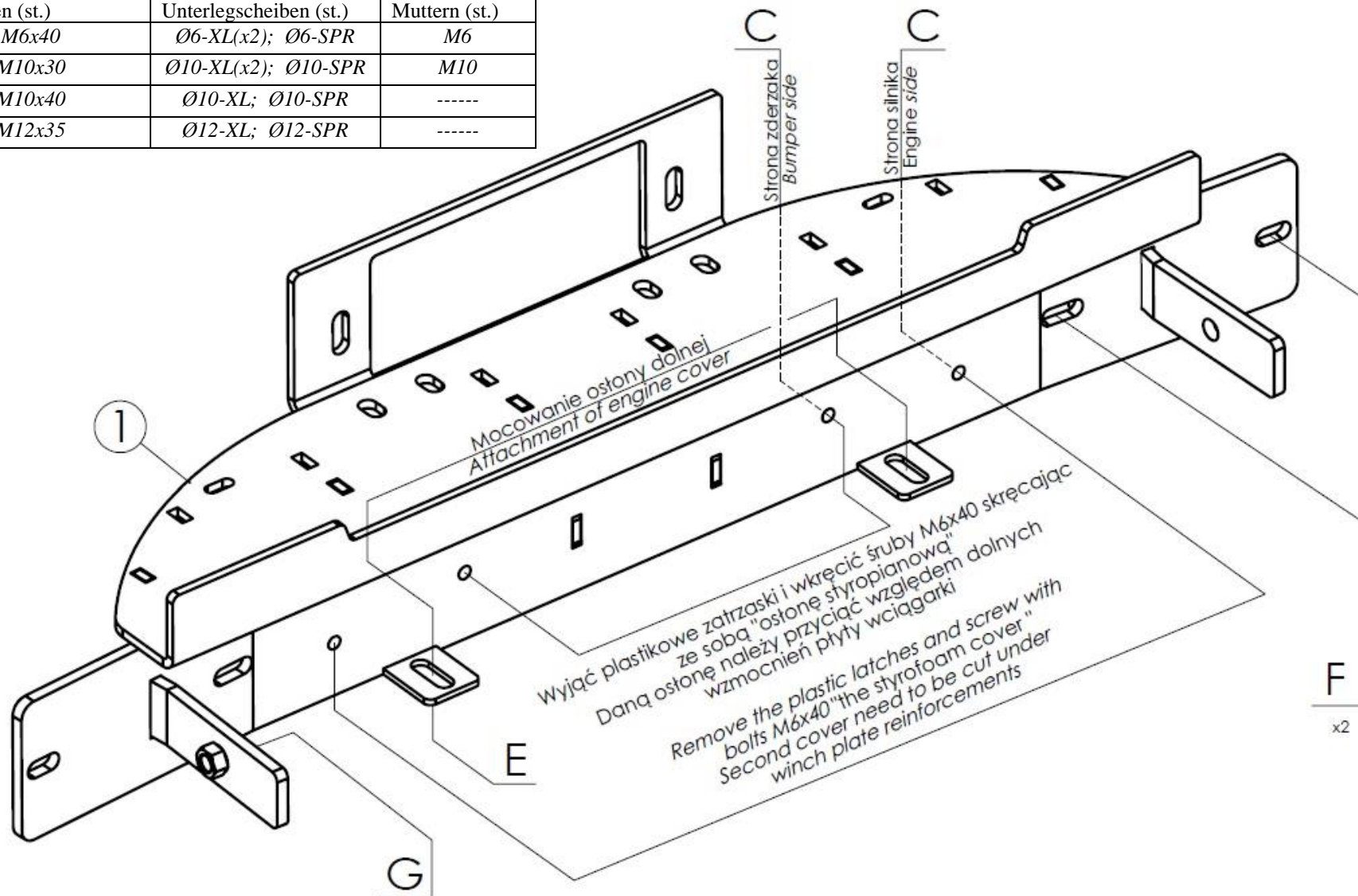

15,4 kg

**Montaż / Fitting / Монтаж / Montage**  
R12-PW-R / R12-PW-R

	Śruby (szt.) Screws (pcs.) Болты (шт.) Schrauben (st.)	Podkładki (szt.) Washers (pcs.) Шайбы (шт.) Unterlegscheiben (st.)	Nakrętki (szt.) Nuts (pcs.) Гайки (шт.) Muttern (st.)
<b>C</b>	M6x40	Ø6-XL(x2); Ø6-SPR	M6
<b>D</b>	M8x80	Ø8(x2); Ø8-SPR	M8
<b>E</b>	M10x30	Ø10-XL(x2); Ø10-SPR	M10
<b>F</b>	M10x40	Ø10-XL; Ø10-SPR	-----
<b>G</b>	M12x35	Ø12-XL; Ø12-SPR	-----

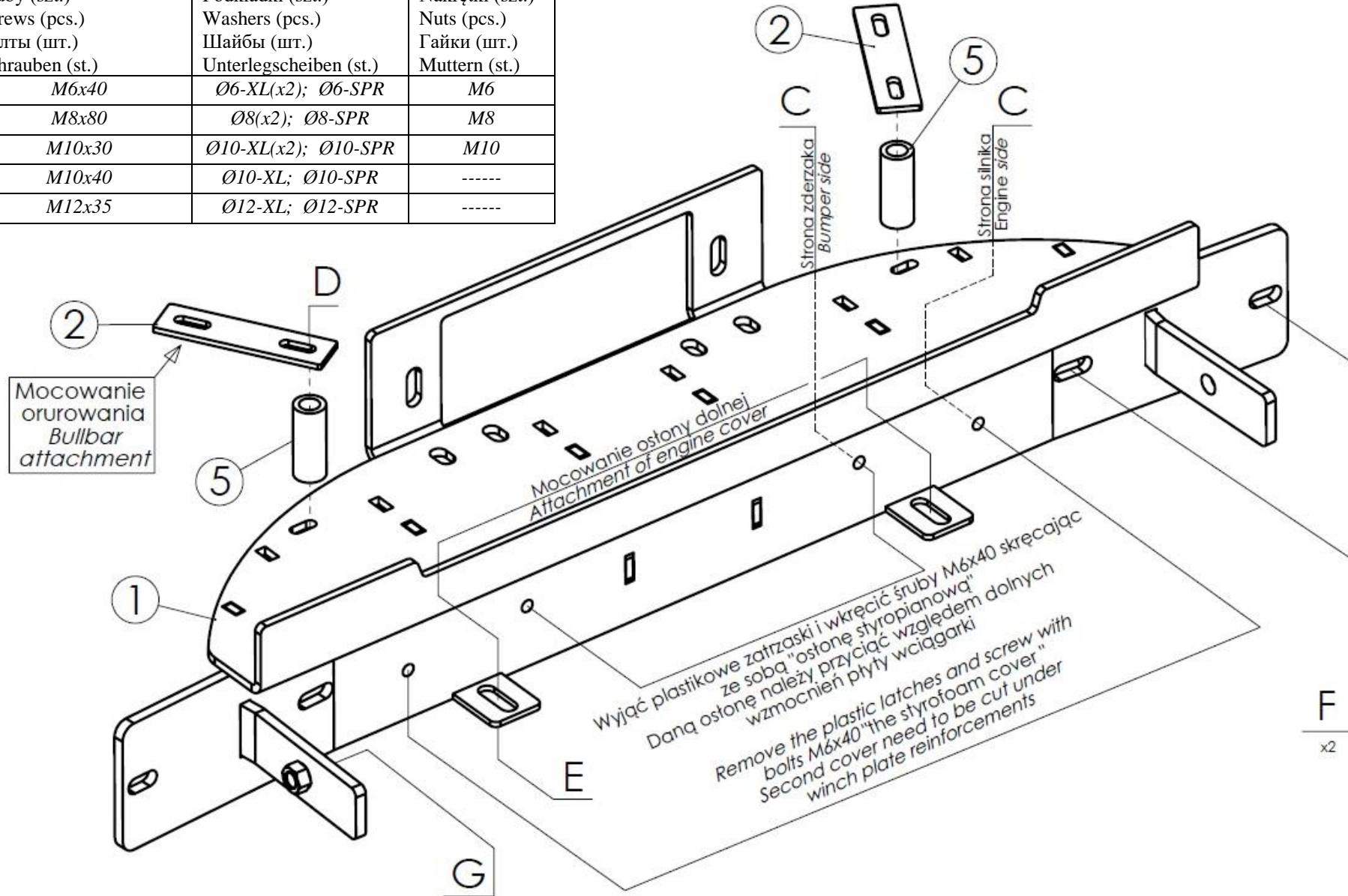

15,9 kg

**Montaż / Fitting / Монтаж / Montage**  
**R16-PW-RADAR**

	Śruby (szt.) Screws (pcs.) Болты (шт.) Schrauben (st.)	Podkładki (szt.) Washers (pcs.) Шайбы (шт.) Unterlegscheiben (st.)	Nakrętki (szt.) Nuts (pcs.) Гайки (шт.) Muttern (st.)
<b>A</b>	M6x30	Ø6-XL(x2); Ø6-SPR	M6 (sam./lock)
<b>B</b>	M6x40	Ø6-XL(x2); Ø6-SPR	M6 (sam./lock)
<b>C</b>	M6x40	Ø6-XL(x2); Ø6-SPR	M6
<b>E</b>	M10x30	Ø10-XL(x2); Ø10-SPR	M10
<b>F</b>	M10x40	Ø10-XL; Ø10-SPR	-----
<b>G</b>	M12x35	Ø12-XL; Ø12-SPR	-----

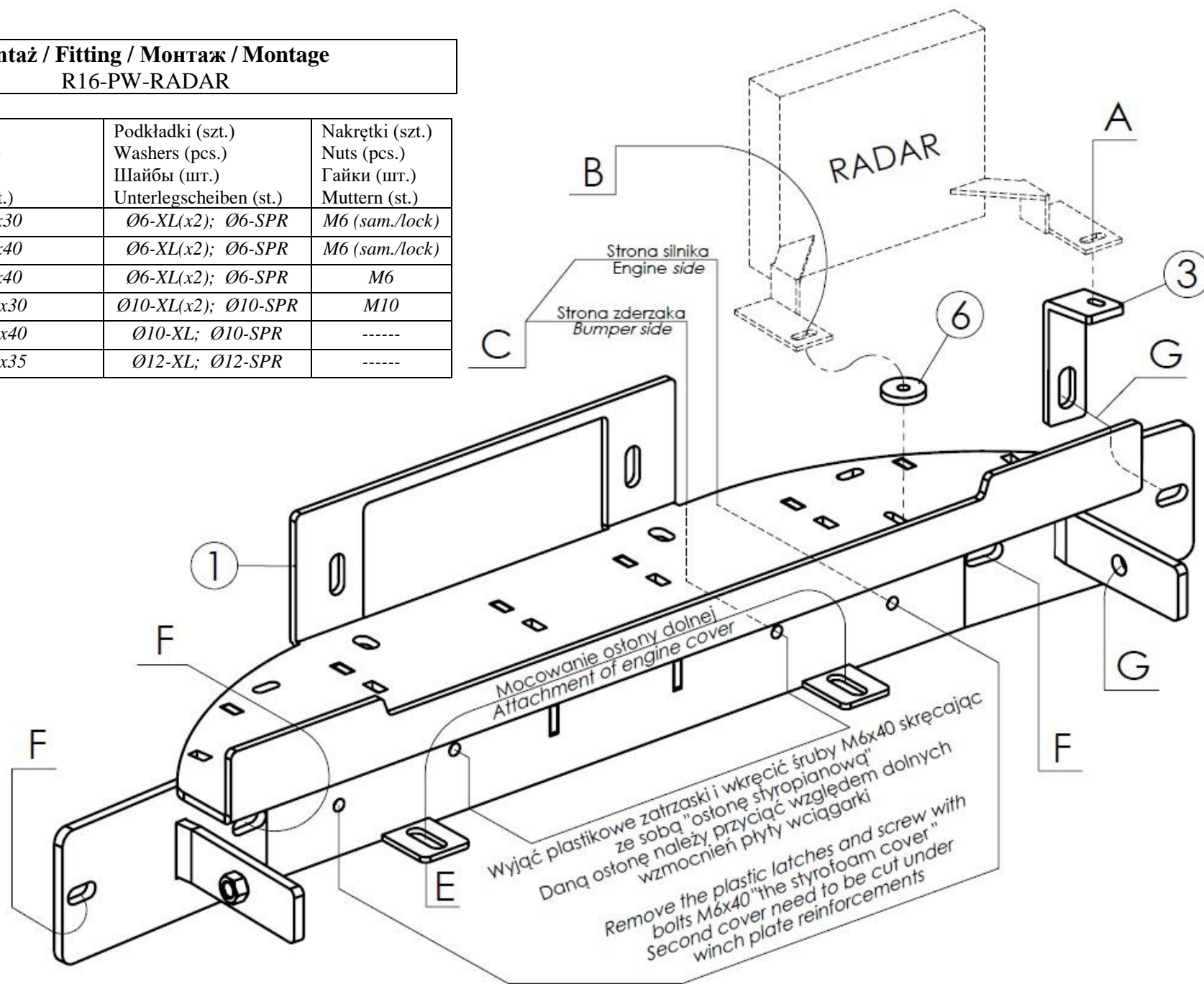

15,9 kg

**Montaż / Fitting / Монтаж / Montage**

Mocowanie pilota i hebla ; Attachment to the control switch and the security main breaker ;  
 Крепление к удаленному / к выключатель; Die Befestigung an dem Entfernten / Leistungsschalter

Montowanie hebla pod maską  
 Mounting the security main breaker

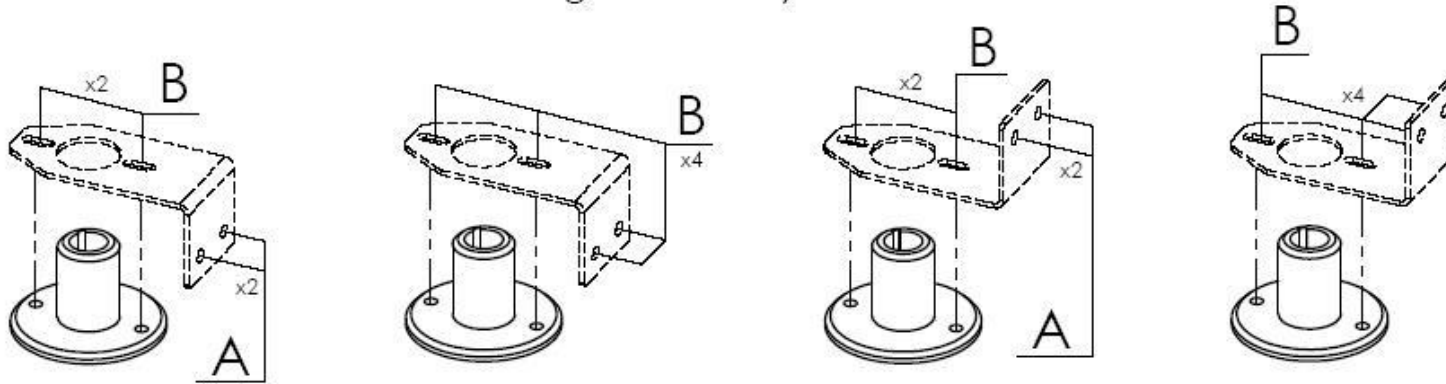

Montowanie pilota pod maską  
 Mounting the control switch

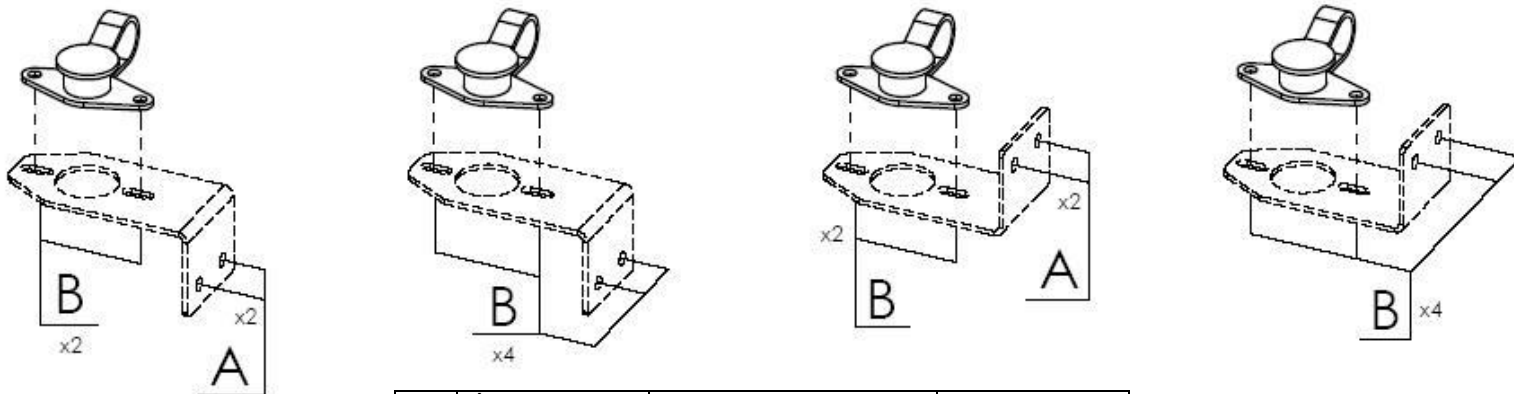

	Śruby (szt.) Screws (pcs.) Болты (шт.) Schrauben (st.)	Podkładki (szt.) Washers (pcs.) Шайбы (шт.) Unterlegscheiben (st.)	Nakrętki (szt.) Nuts (pcs.) Гайки (шт.) Muttern (st.)
<b>A</b>	M4,2x16	.....	.....
<b>B</b>	M5x20	Ø5 – XL	M5

*Montaż (zdjęcia) / Fitting (pictures) / Монтаж (фотографии)  
/ Montage (Fotos) - R12-PW / R16-PW*



*Należy zdjąć boczne osłony  
You have to take off a side covers*







Należy zdjąć belkę przednią  
*You have to take off a front beam*

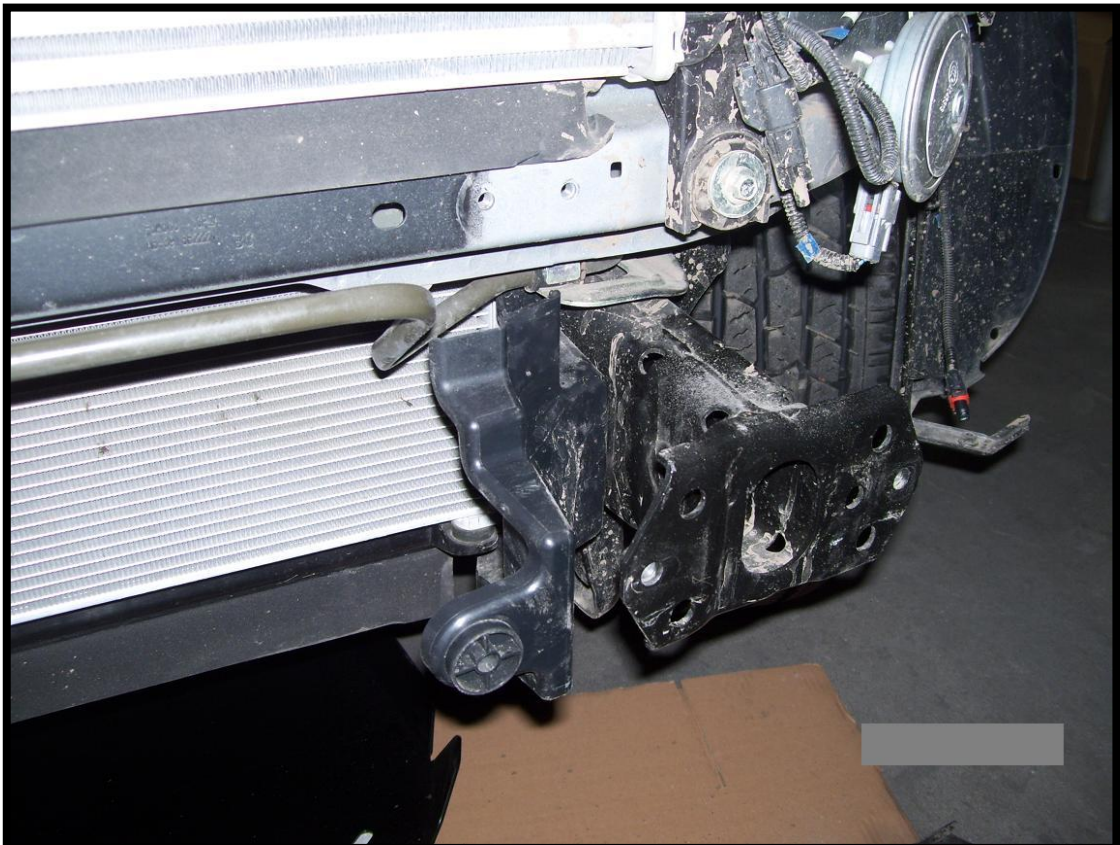

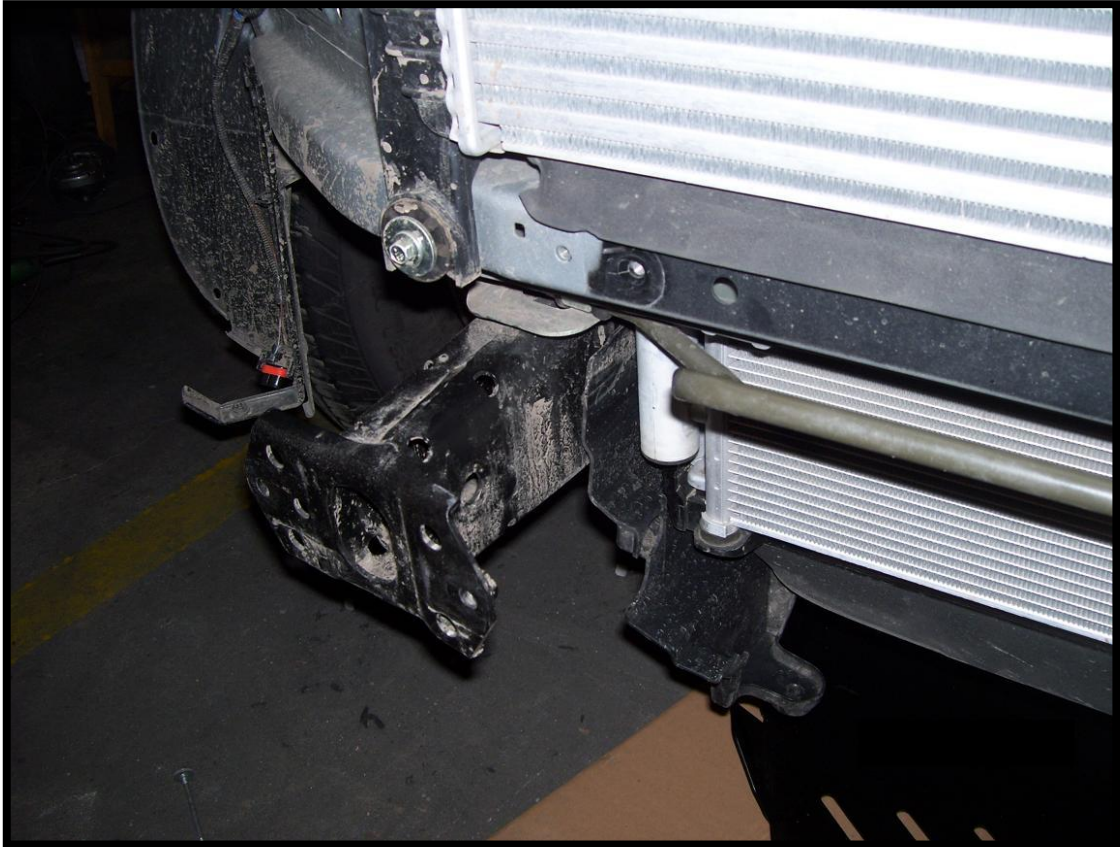

Montowanie płyty wciągarki  
*Mounting of the winch plate*

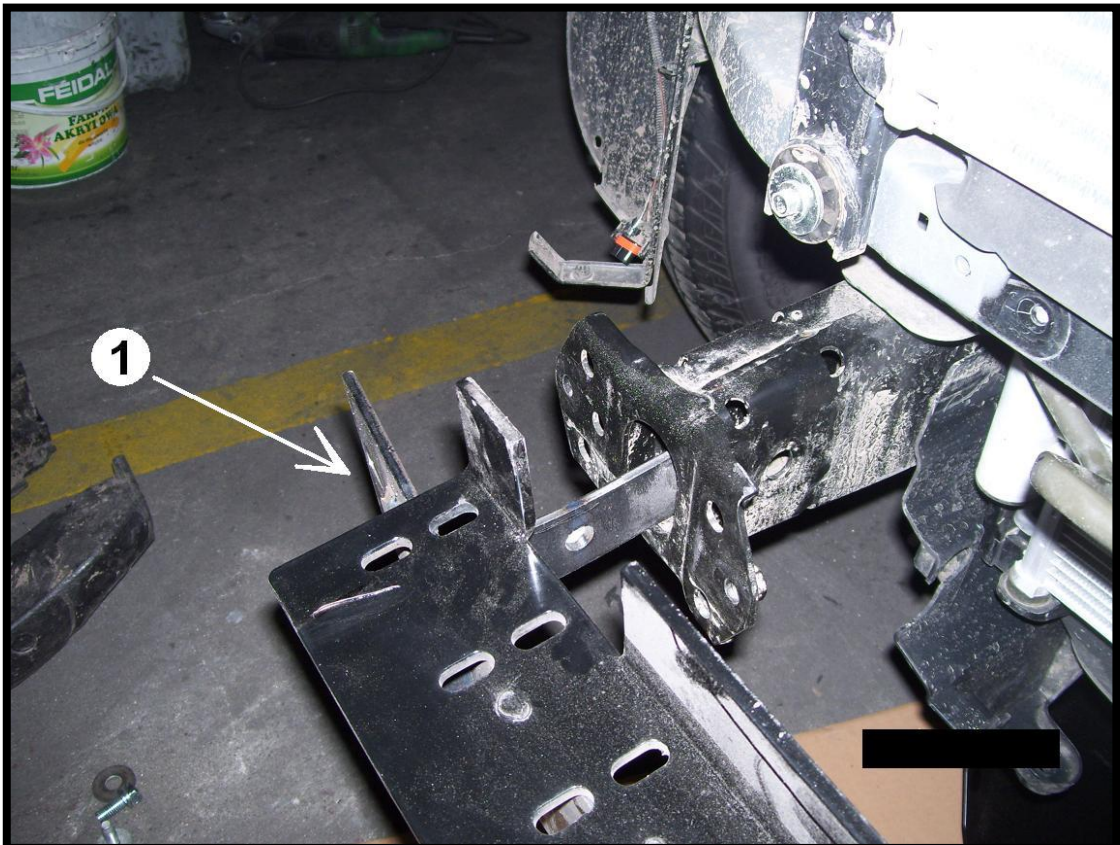

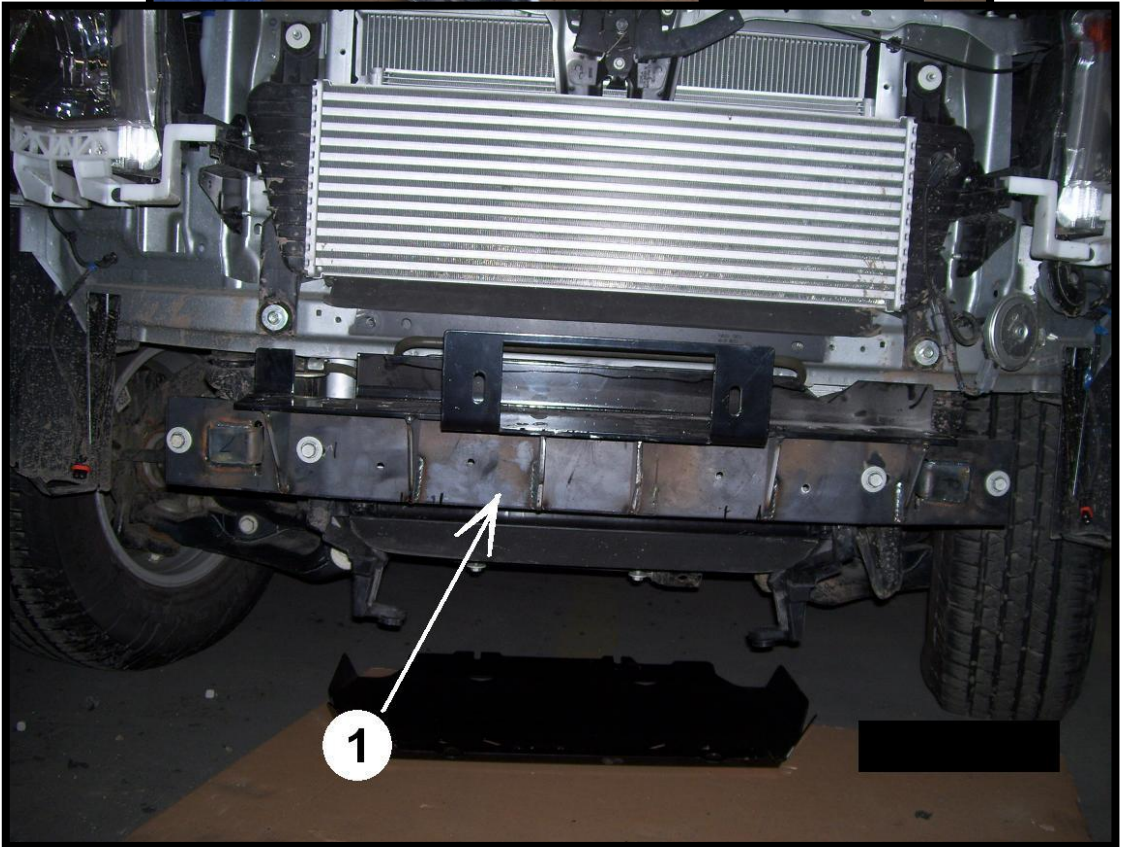
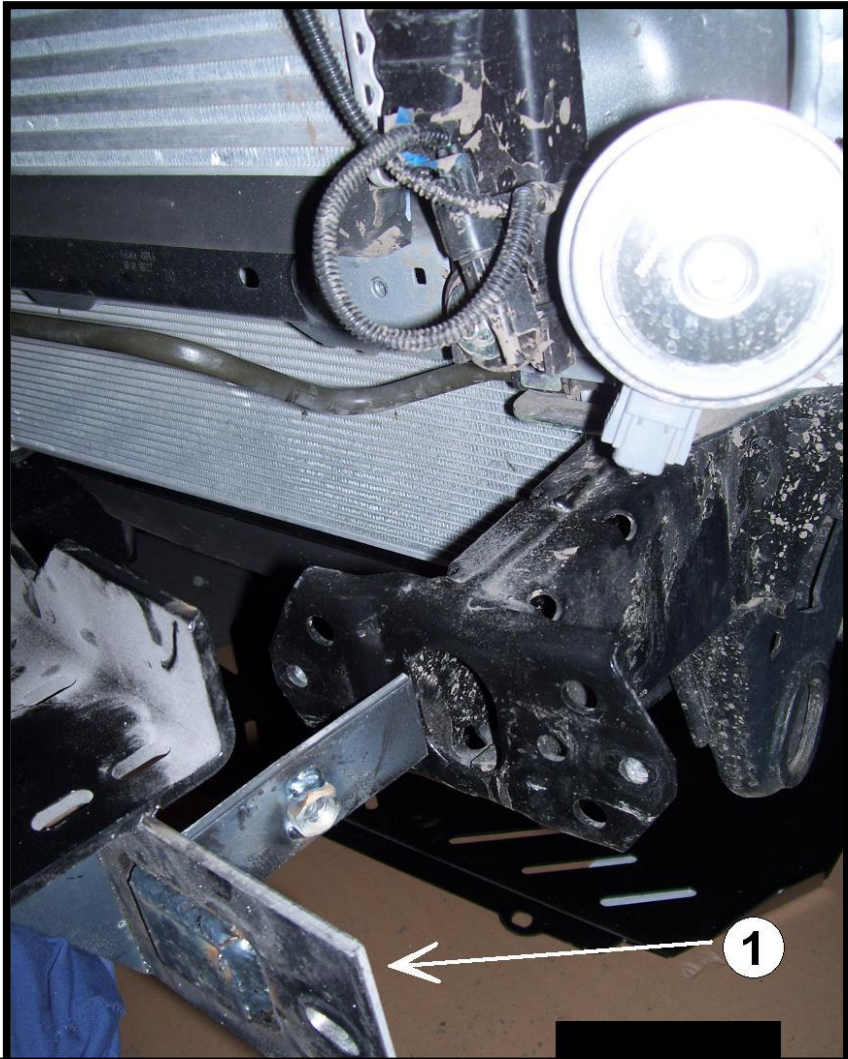

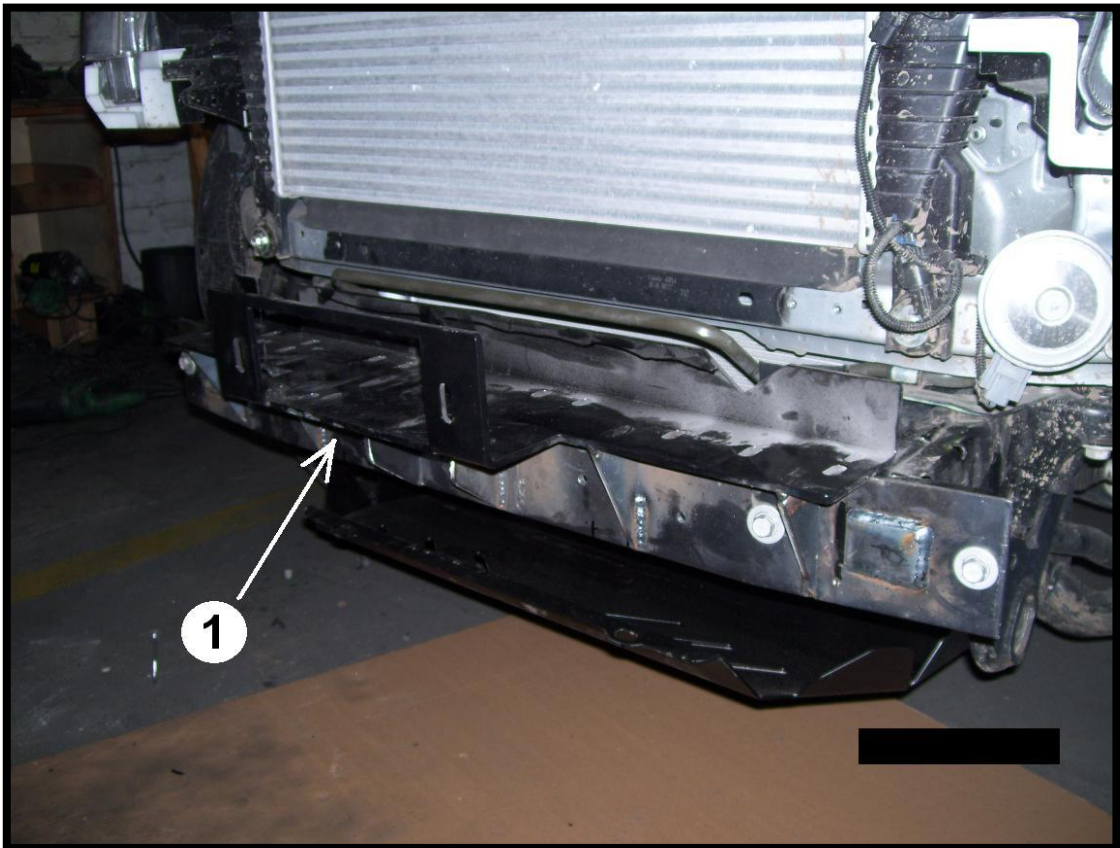
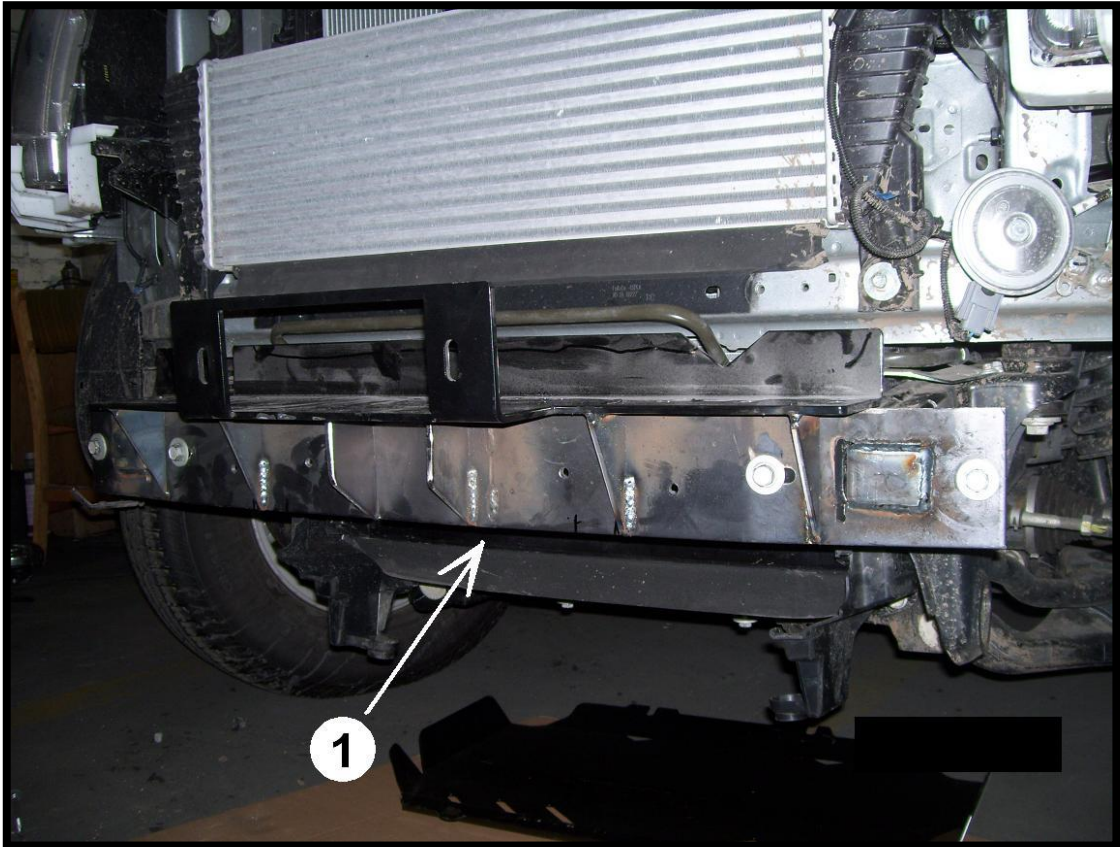



Przykręcenie bocznych części wyciągarki  
*Screwing the sides of the winch plate*

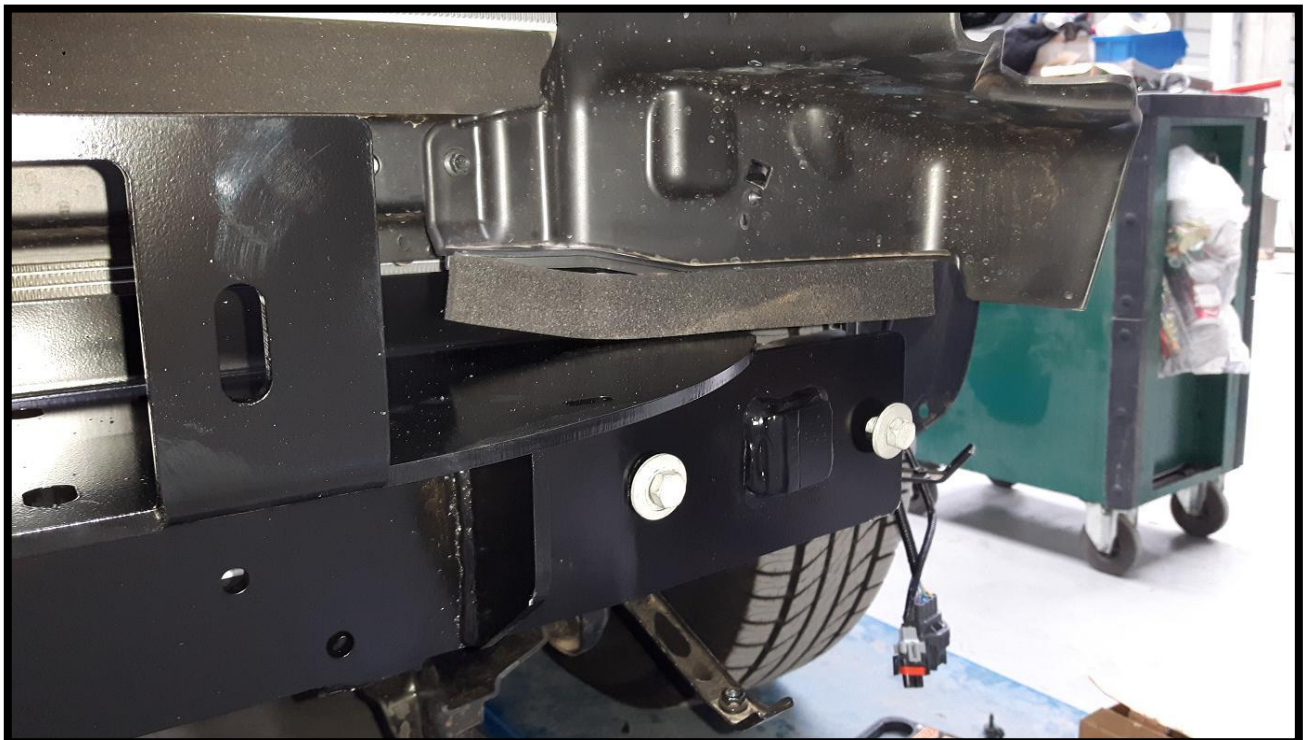

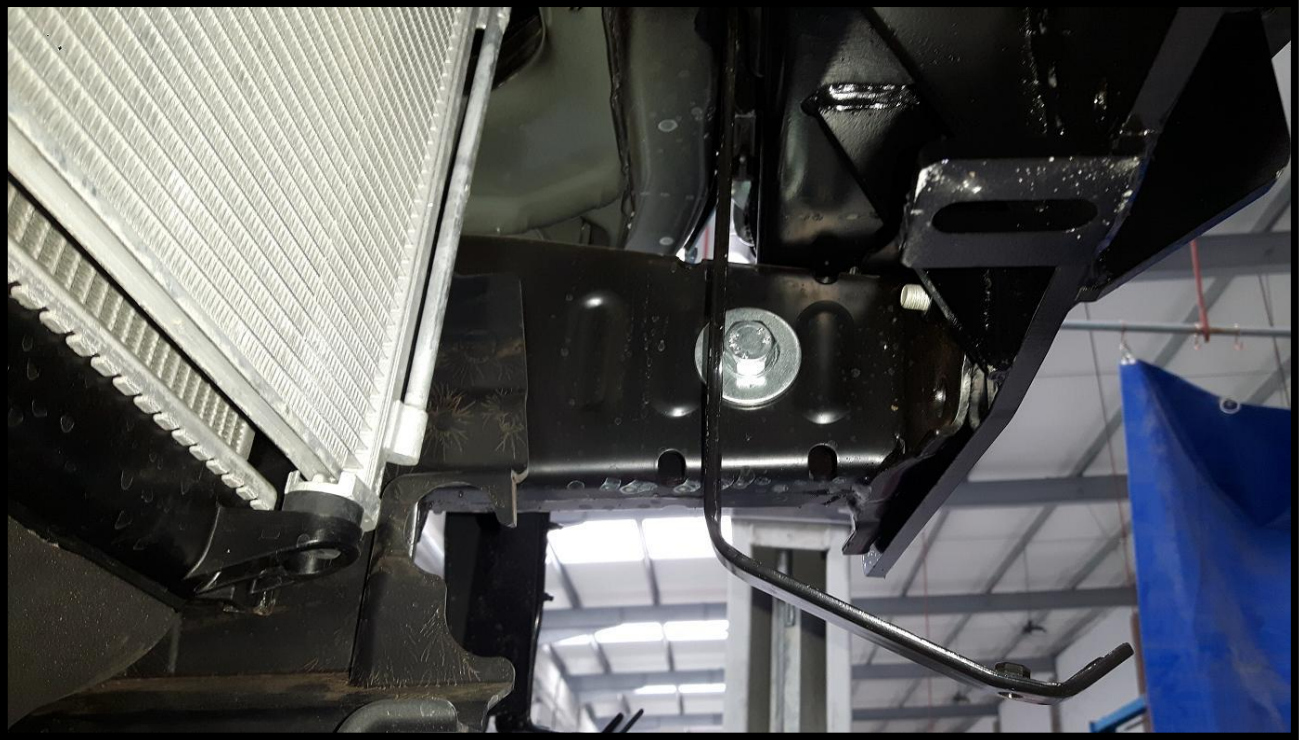



Uchwyt dźwigni przełączającej należy zdemontować i obrócić o 90 stopni, tak aby dana dźwignia znajdowała się z przodu wyciągarki.  
*Switching lever handle must be removed and rotated 90 degrees, so that the lever was on the front.*





Montowanie wyciągarki  
Mounting the winch





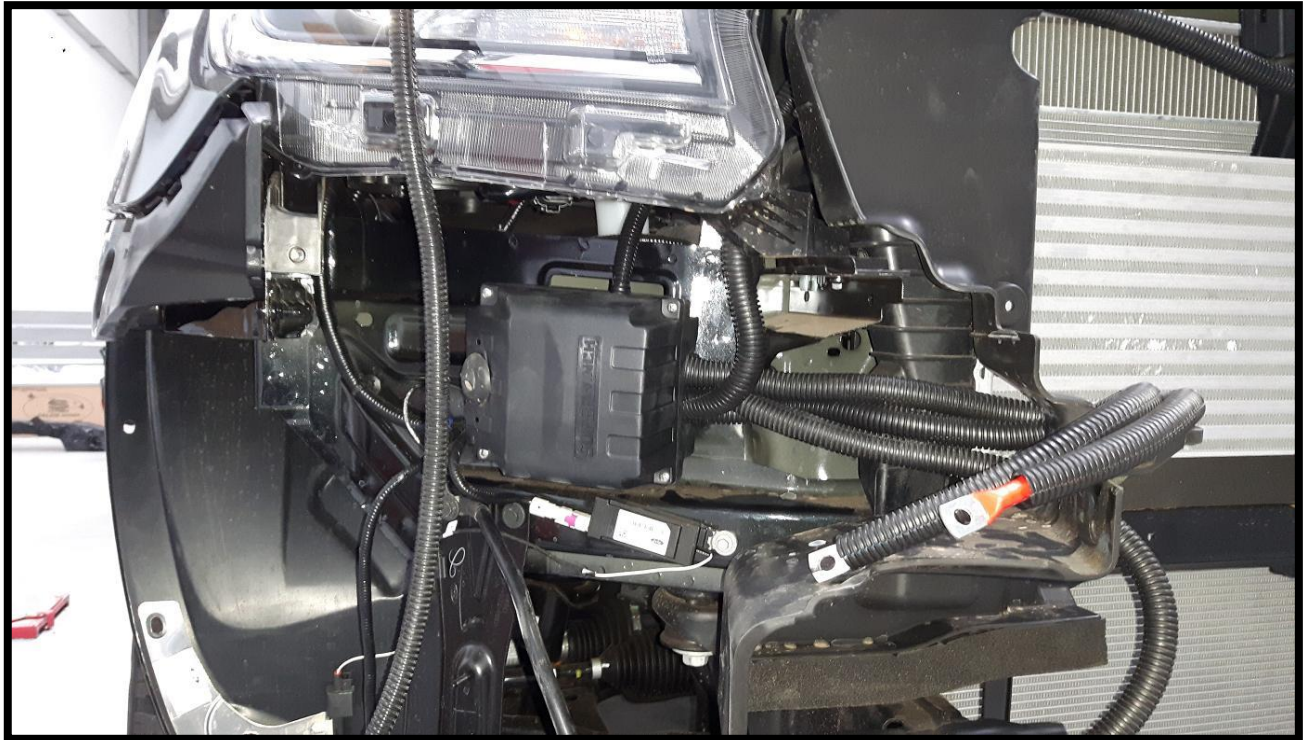

Montowanie przekaźnika.  
*Mounting the relay.*



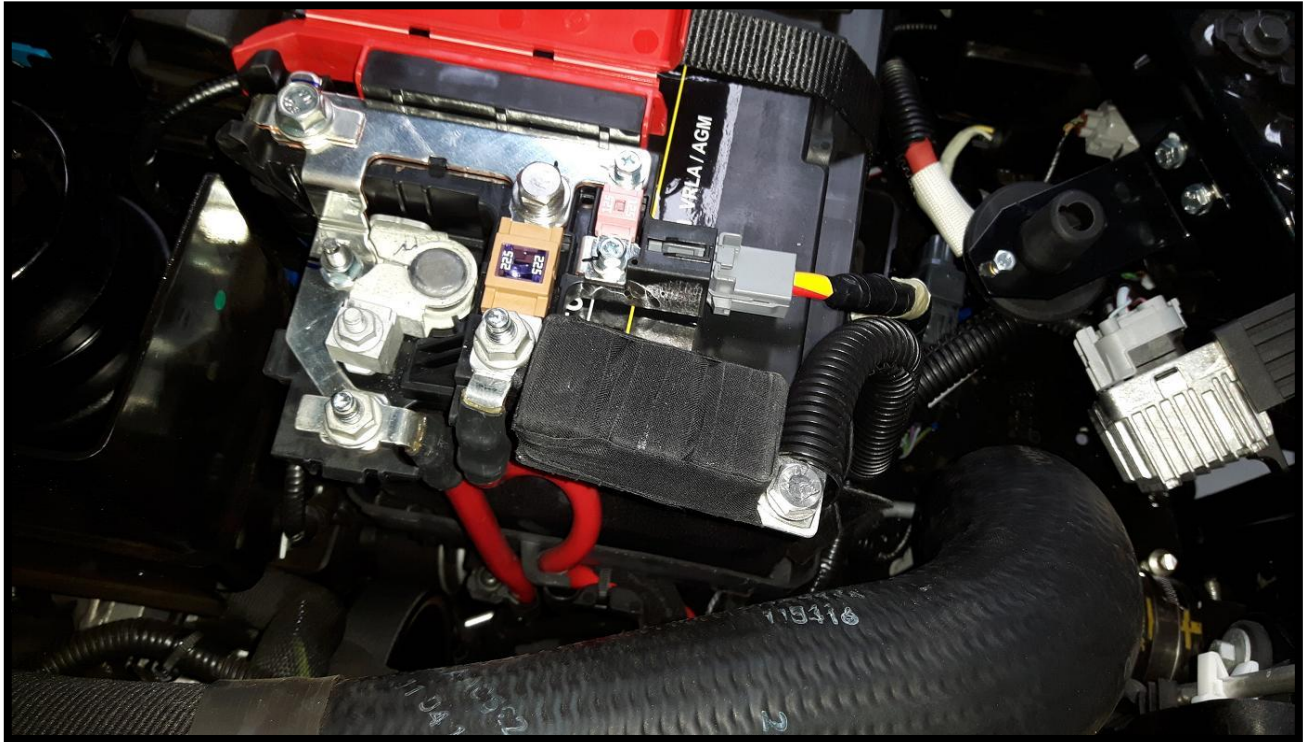

Podłączanie przekaźnika.

Trzy przewody (H07V-K 1x35) z końcówkami (8x35).

Podłączanie wyciągarki do akumulatora.

Bezpiecznik należy zamocować bezpośrednio do akumulatora a następnie należy zamocować czerwony przewód do danego bezpiecznika.

Hebel zabezpieczający (główny wyłącznik prądu) montuje się w dowolnym miejscu pod maską.

*Wiring the relay.*

*Three wires (H07V-K 1x35) and tips (8x35).*

*The fuse must be mounted directly to the battery and then attach the red wire to the fuse.*

*Connecting the winch to the car battery.*

*Security main breaker is mounted anywhere under the hood.*

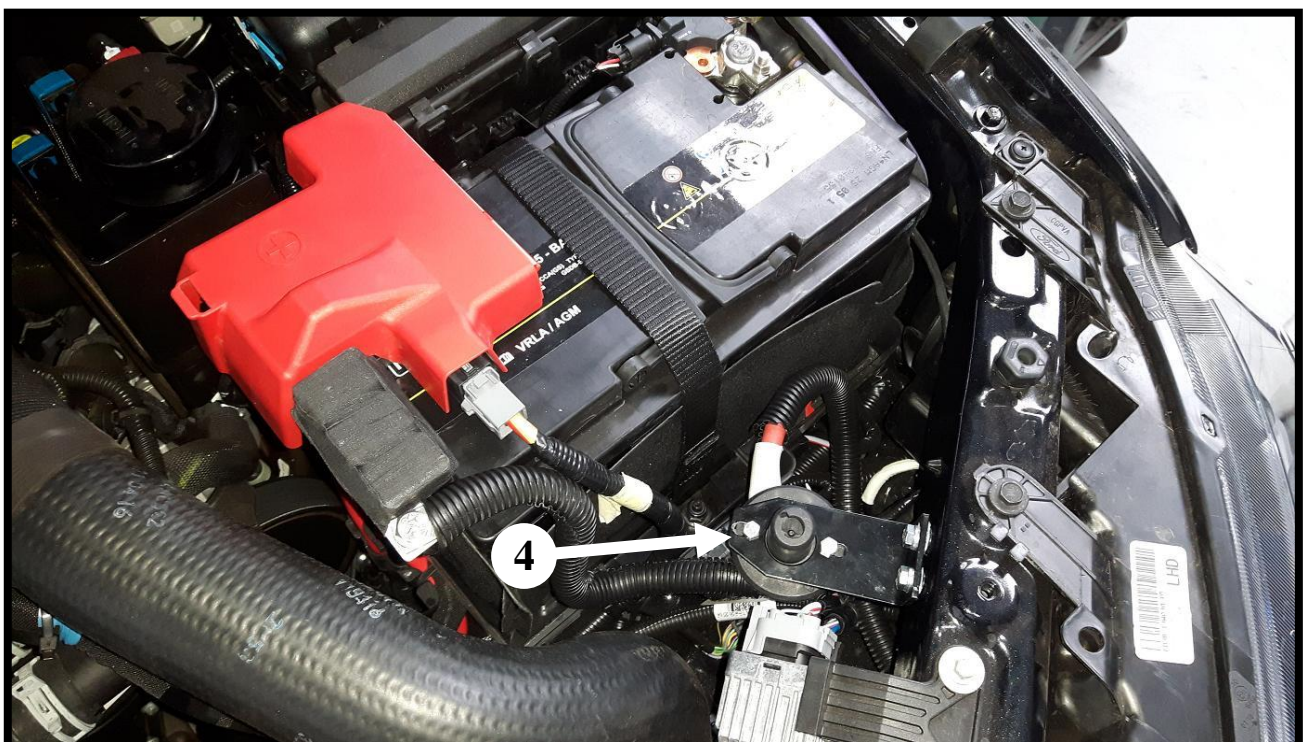



Montowanie pilota. Zabezpieczyć podkładem przed korozją.  
*Mounting control switch attachment. Protect against corrosion with primer.*

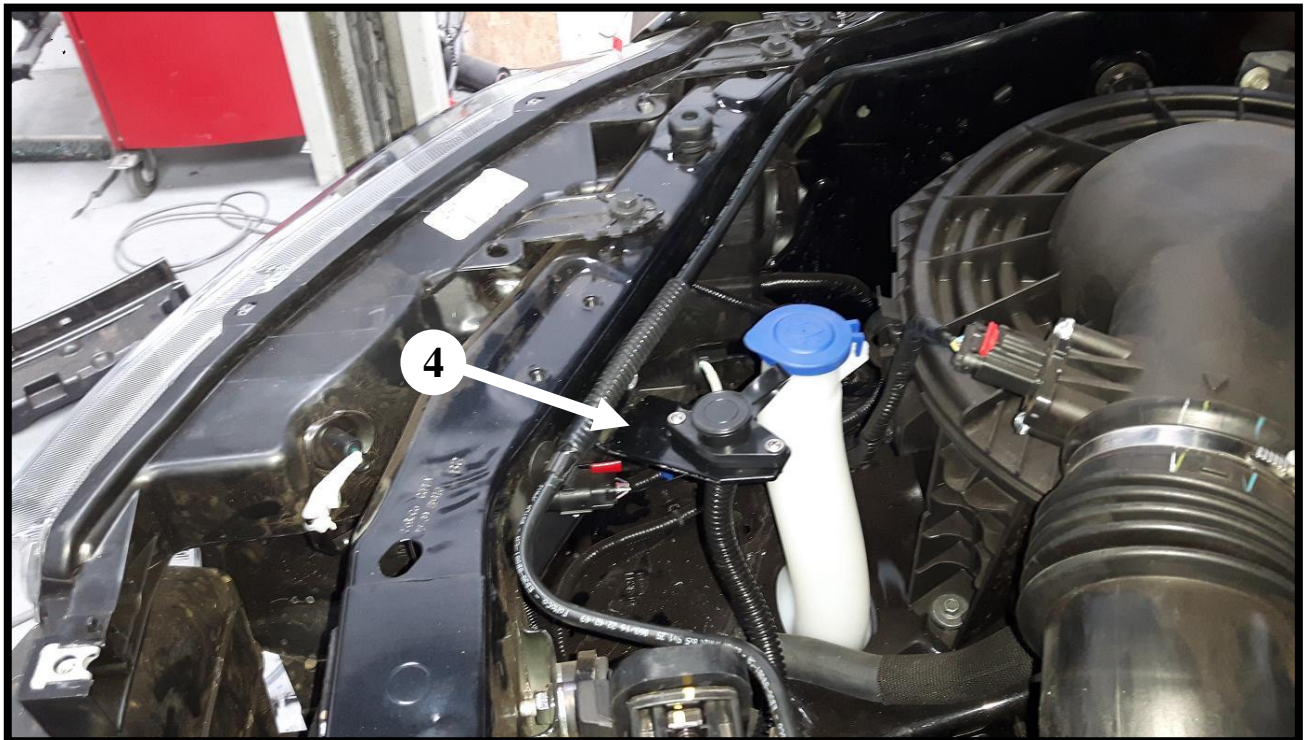



Dopasowanie i montowanie przedniej plastikowej osłony.  
*Adjusting and mounting the front plastic cover.*



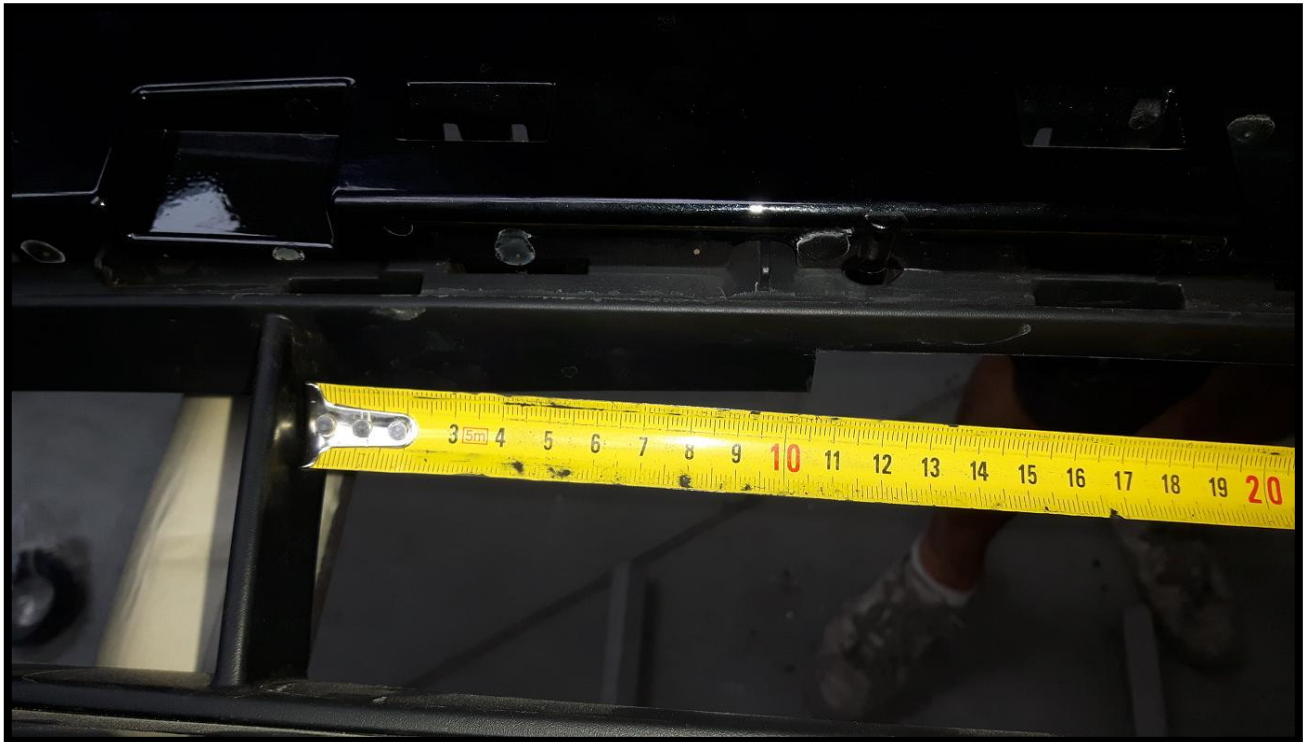

Dopasowanie i montowanie przedniej dolnej belki.  
*Adjusting and mounting the lower front beam.*



Montowanie rolki przedniej .  
*Mounting of the front roller.*



*Montaż (zdjęcia) / Fitting (pictures) / Монтаж (фотографии)  
/ Montage (Fotos) - R16-PW-RADAR*

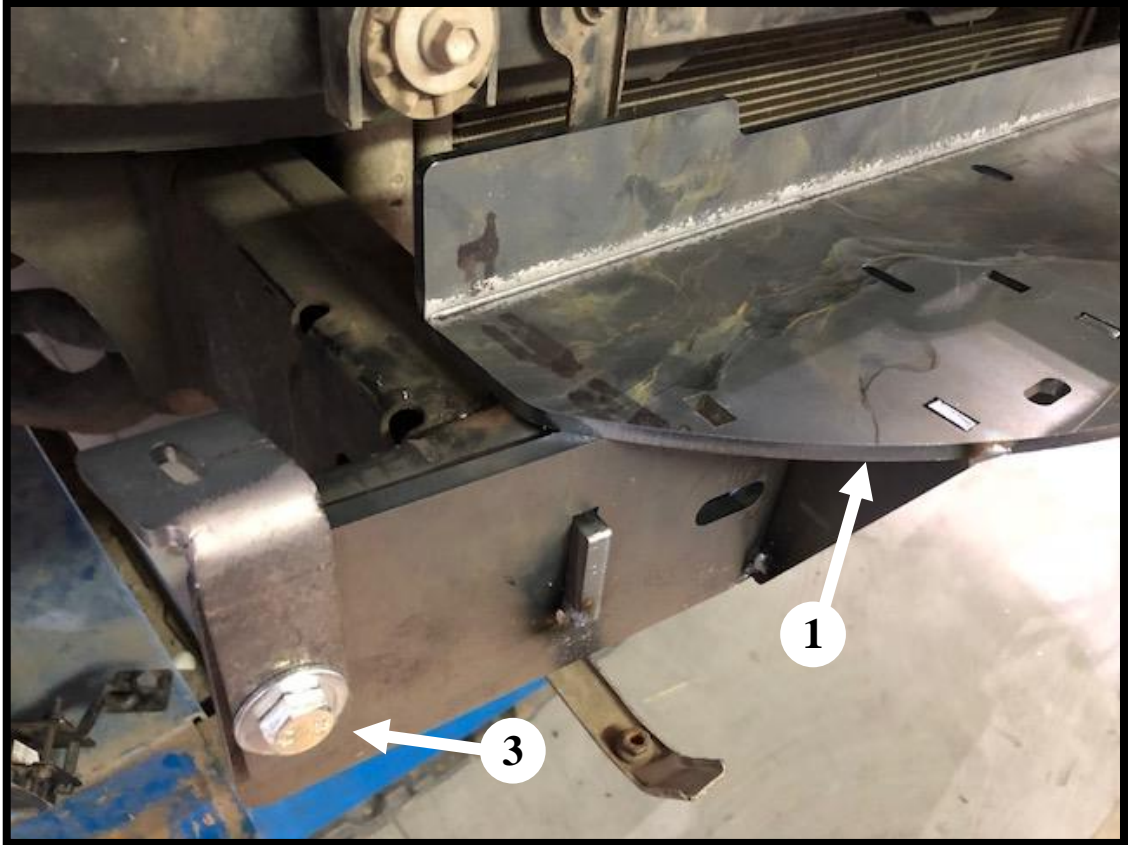

*Dopasowanie i montowanie radaru.  
Adjusting and mounting the radar.*



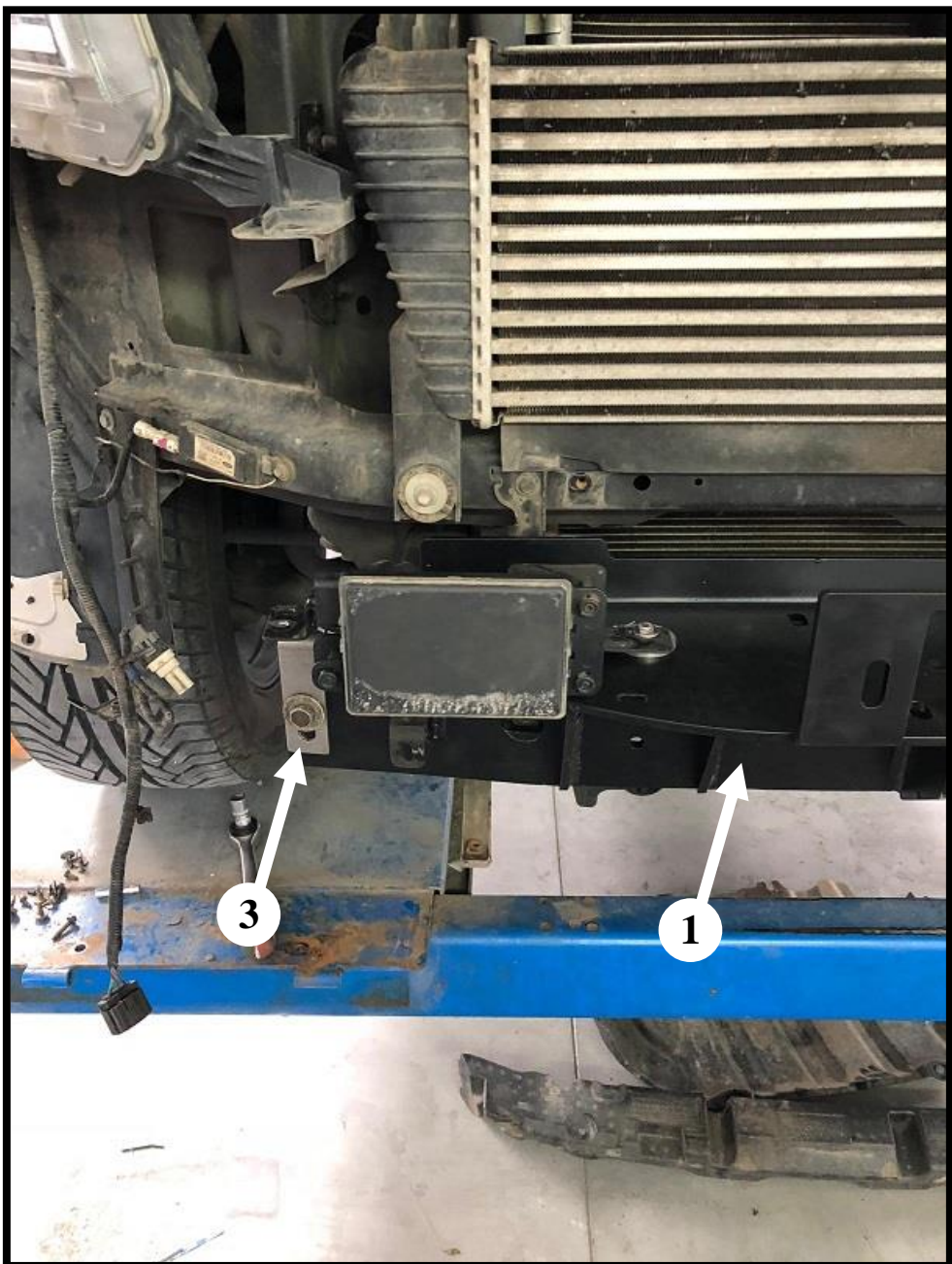
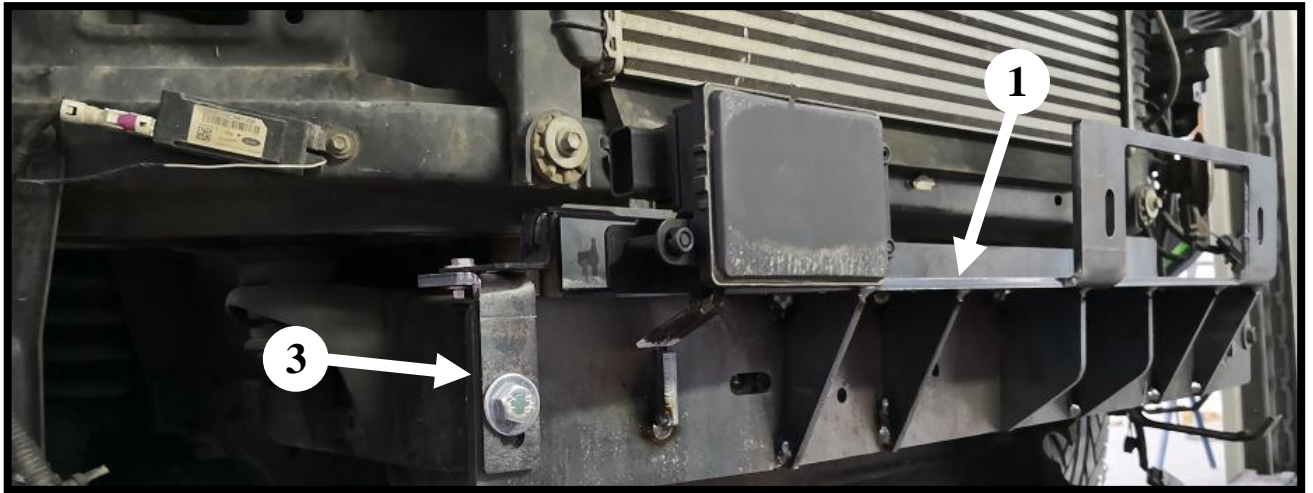



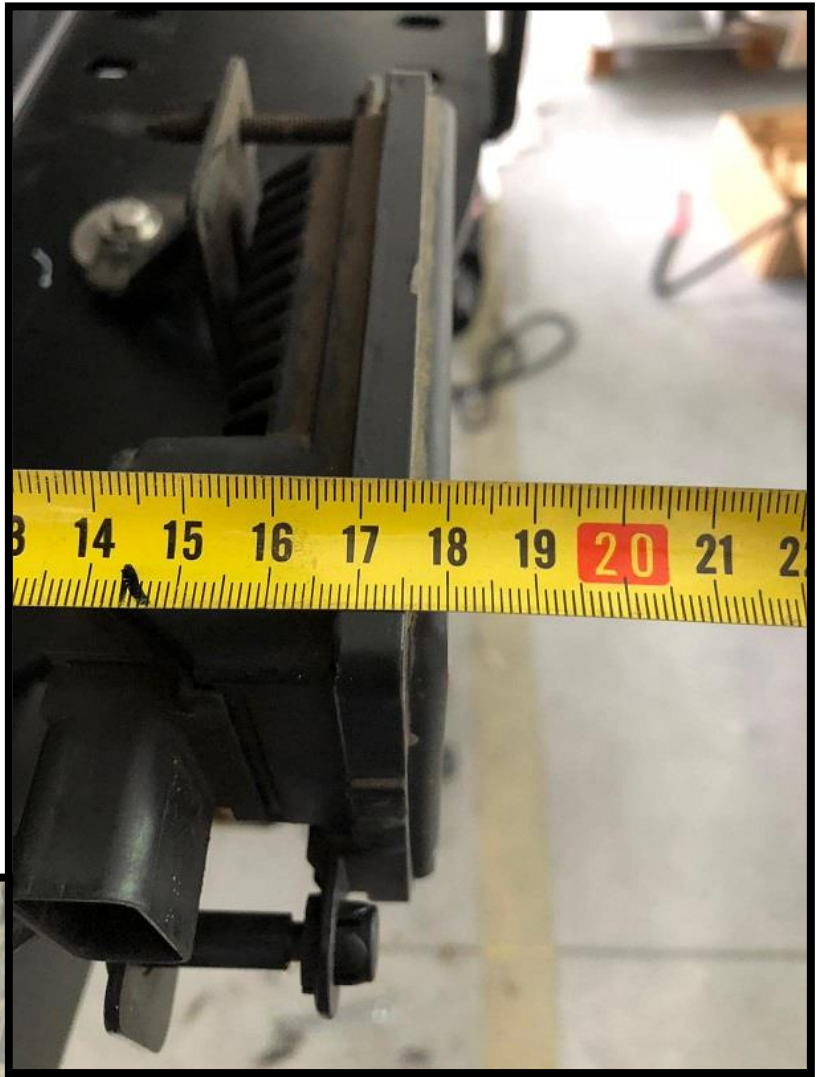

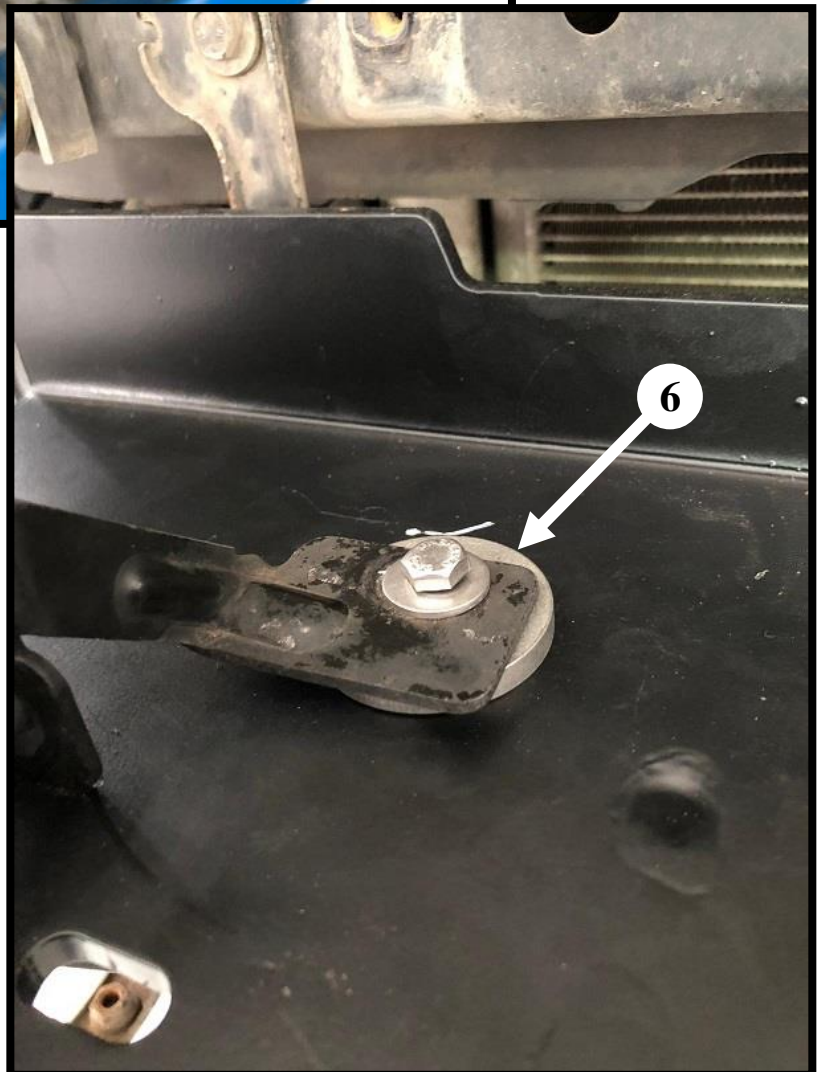
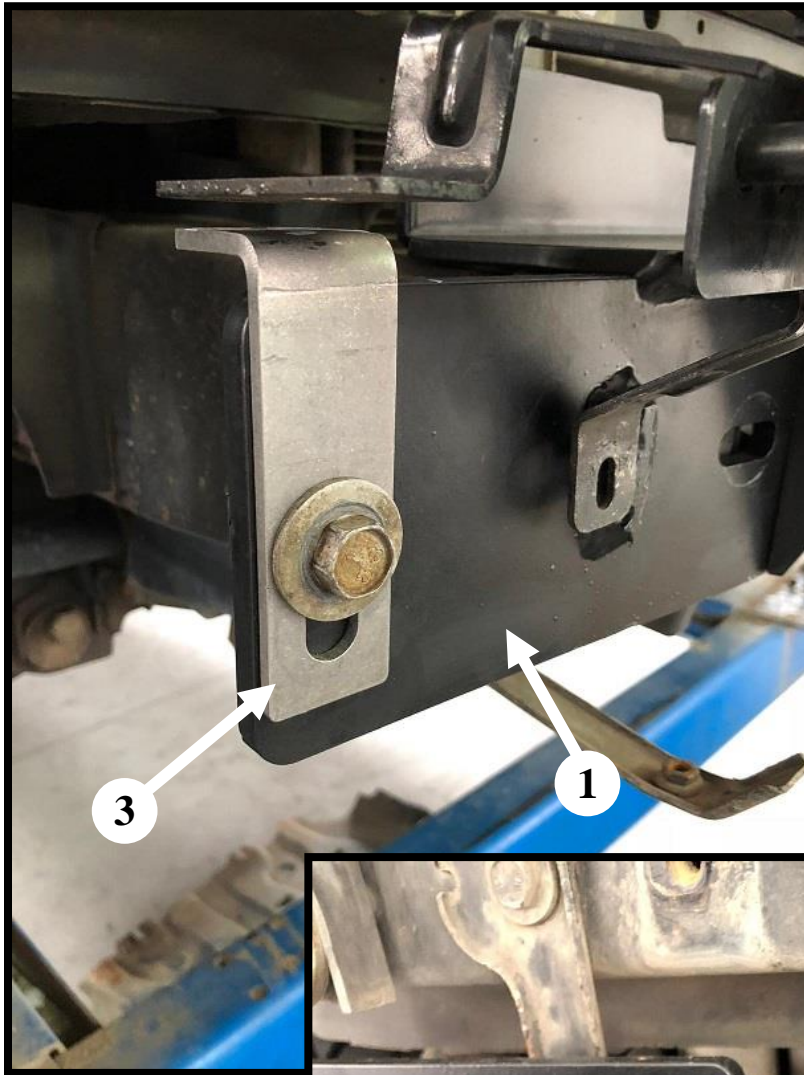



Dopasowanie i montowanie przedniej plastikowej osłony.  
*Adjusting and mounting the front plastic cover.*







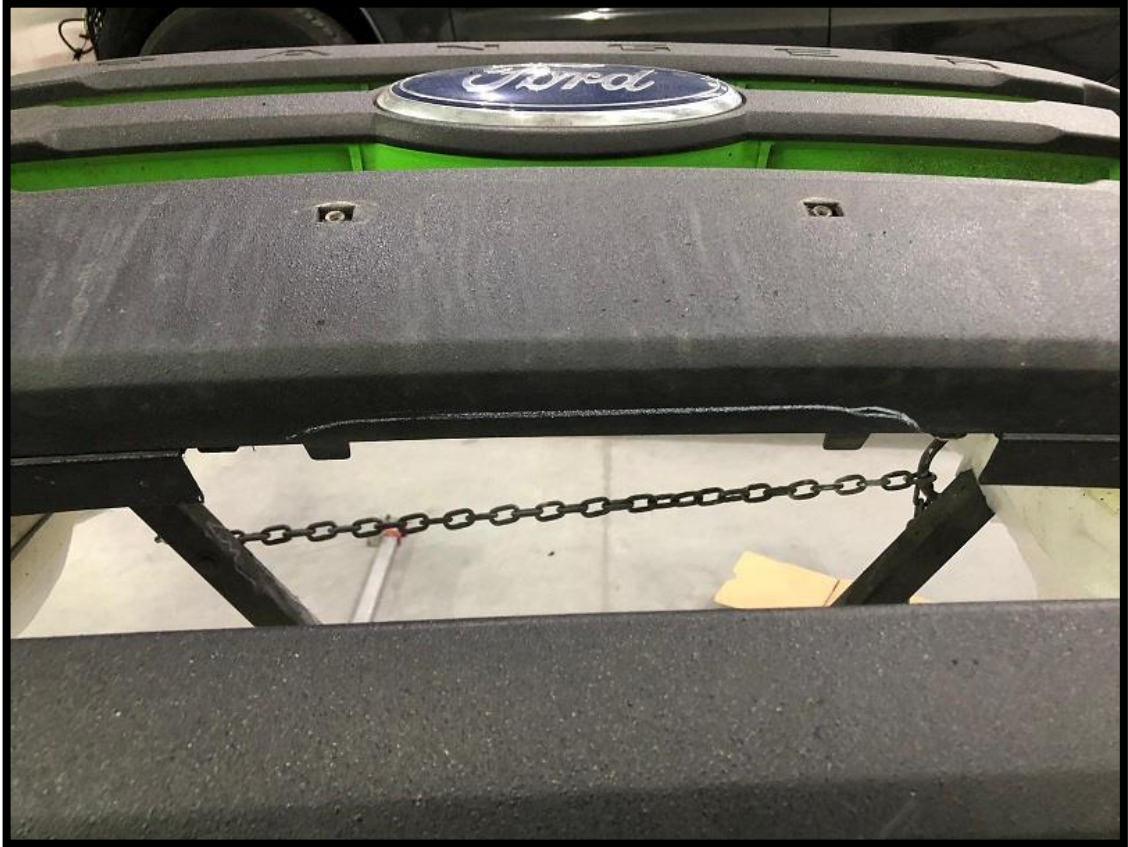



Podłączanie przekaźnika.  
*Wiring the relay.*







Trzy przewody (H07V-K 1x35) z końcówkami (8x35).

Podłączanie wyciągarki do akumulatora.

Bezpiecznik należy zamocować bezpośrednio do akumulatora a następnie należy zamocować czerwony przewód do danego bezpiecznika.

Hebel zabezpieczający (główny wyłącznik prądu) montuje się w dowolnym miejscu pod maską.

*Three wires (H07V-K 1x35) and tips (8x35).*

*The fuse must be mounted directly to the battery and then attach the red wire to the fuse.*

*Connecting the winch to the car battery.*

*Security main breaker is mounted anywhere under the hood.*

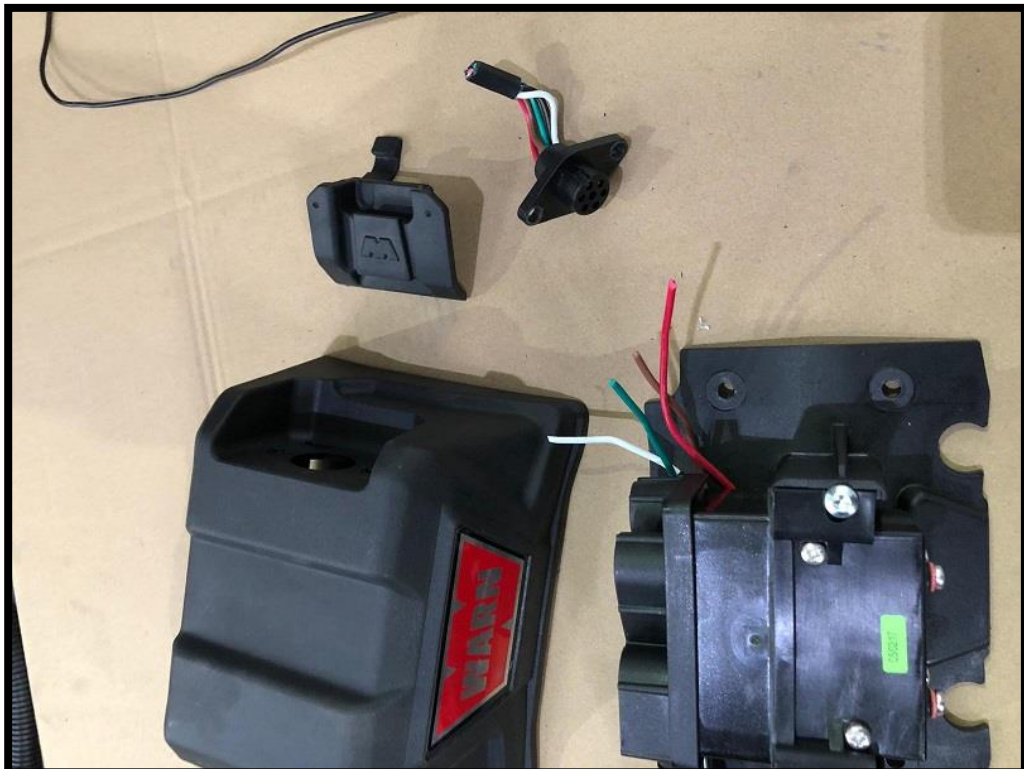

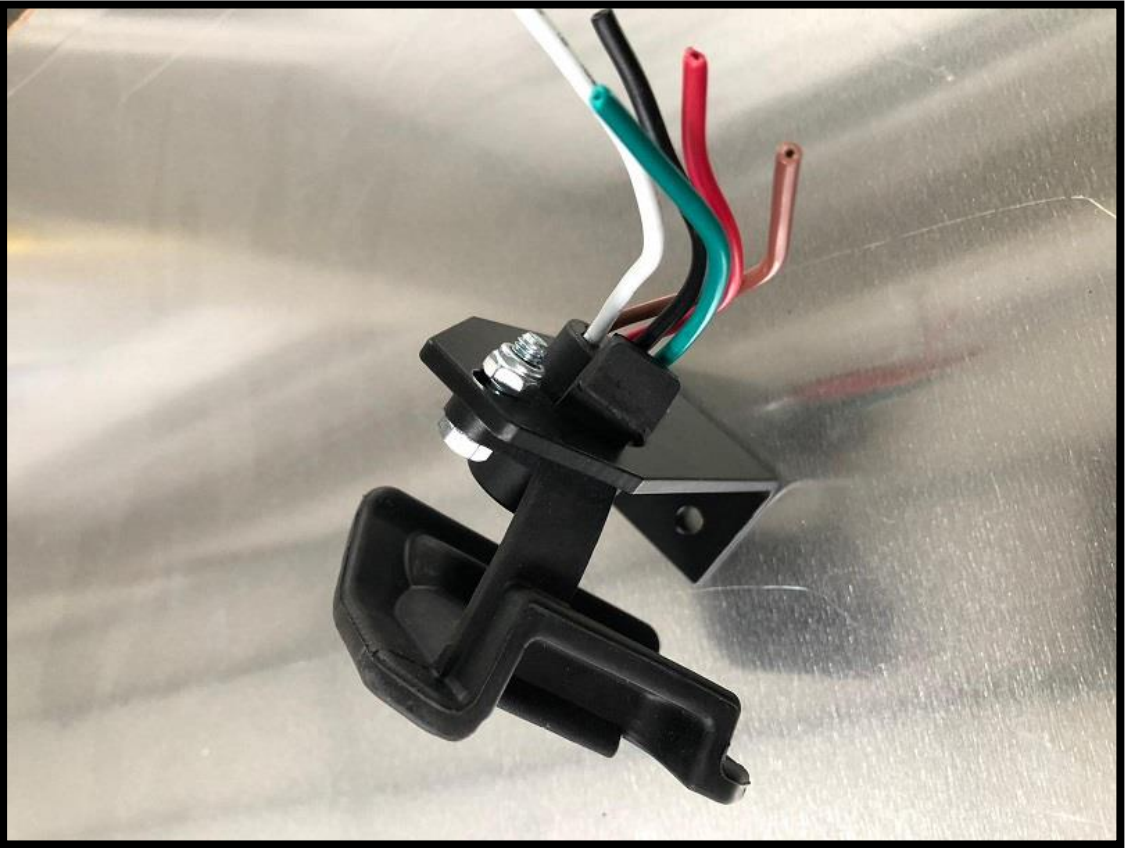



Montowanie wyciągarki  
Mounting the winch



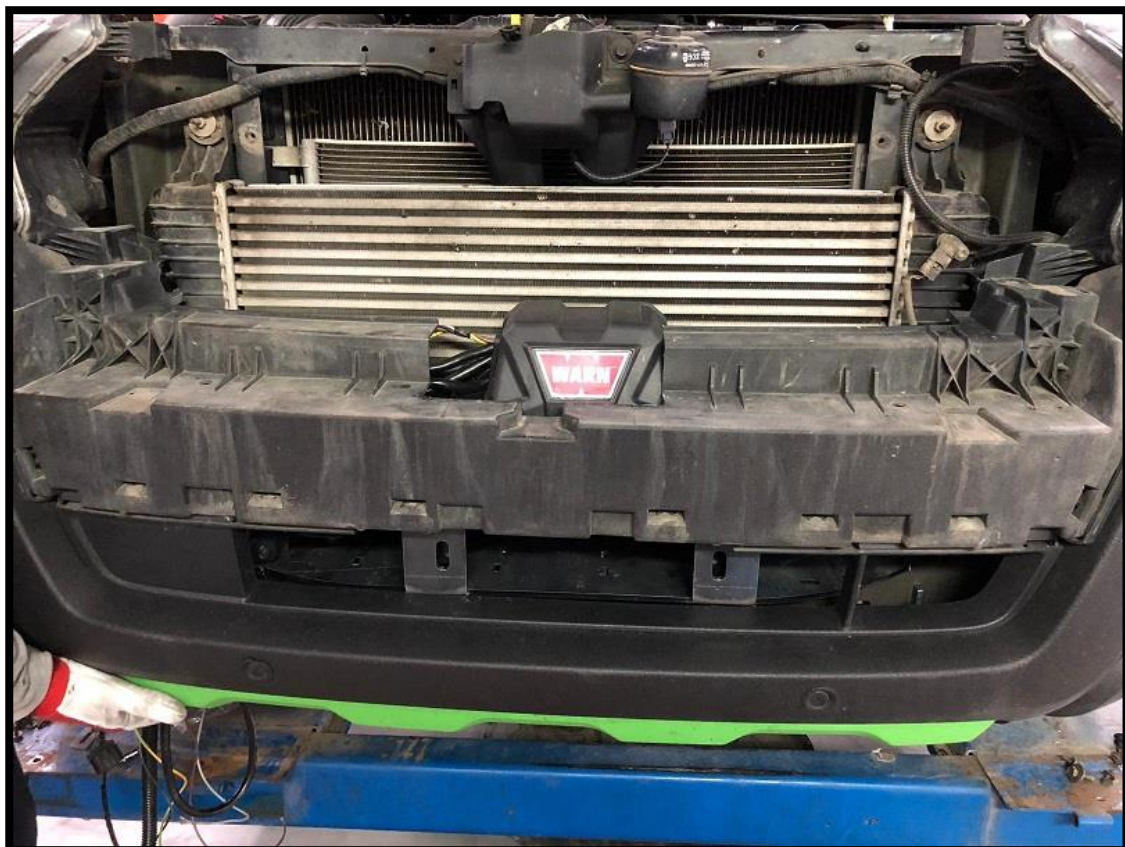

Montowanie pilota.  
*Mounting control switch attachment.*

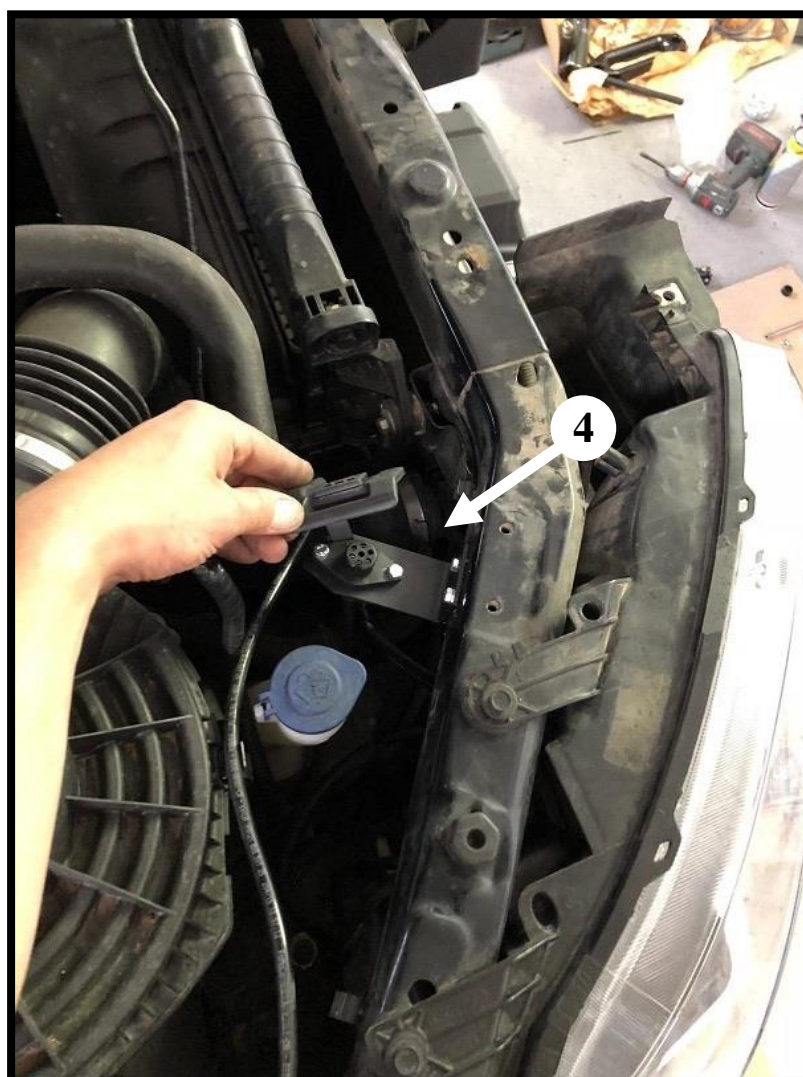

Hebel zabezpieczający (główny wyłącznik prądu)  
montuje się w dowolnym miejscu pod maską.  
*Security main breaker is mounted anywhere under the hood.*

